

irus PRE2000W4

Instructions - page 1 of 4

Single element hot water tank control kit



Cleverly simple
control of energy.

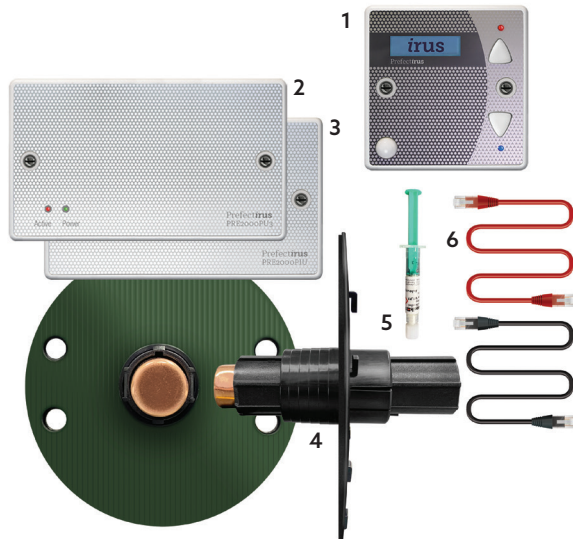

Kit components:

- 1 PRE2000CU3 Control unit
- 2 PRE2000PU3 Power unit
- 3 PRE2000PIU Probe interface unit
- 4 PRE2000TTS2-B Lower Temperature probe
PRE2000TTS2-R Upper Temperature probe
- 5 Thermal paste
- 6 RJ45 patch leads



All wiring should be carried out by a competent electrician working in accordance with current regulations.

Identify the appropriate power supply and perform procedures to ensure all circuits are completely isolated.

The supply should be locked in the OFF position and safe working practices should always be observed.

The PRE2000W-4 Kit contains all you will need to control a single element hot water system, **except for a double pole isolator**, for isolating the control equipment from the mains supply.

SPECIFICATION AND COMPONENT PARTS

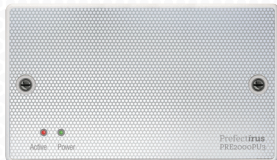

PRE2000PU3

The POWER UNIT provides Separate Extra Low Voltage or SELV, and a 16 Amp switching capacity. It has a Red ACTIVE LED that lights when power is being supplied to the element, and a Green POWER LED to show that power is reaching the unit.

- 16A switching capacity
- 230V AC at 50Hz
- Terminal connections mains
 - » Earth x2
 - » Neutral (N) x2
 - » Live in (LIVE)
 - » Load output (LOAD)
- Standard 2 gang fitment
- 2mm² to 4mm² Mains & LV terminal capacity



PRE2000CU3

The CONTROL UNIT has a screen, a PIR motion sensor and UP and DOWN buttons. These buttons allow you to find the CONTROL UNITS serial number and test the elements.



PRE2000PIU

The PROBE INTERFACE UNIT is the link between the TANK TEMPERATURE PROBES and the CONTROL UNIT.



3m Red RJ45 cable
Upper probe > PIU



3m Black RJ45 cable
Lower probe > PIU



300mm RJ45 cable
Power unit > Slave relay



Thermal paste



PRE2000TTS2-R
Upper probe



PRE2000TTS2-B
Lower probe

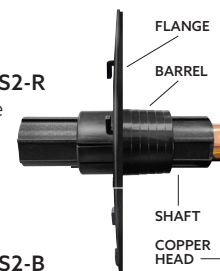

Due to our policy of continuous improvement, we reserve the right to change specifications without notice. All information was correct at time of when this product file was produced - April 2022



Cleverly simple
control of energy.

WIRING

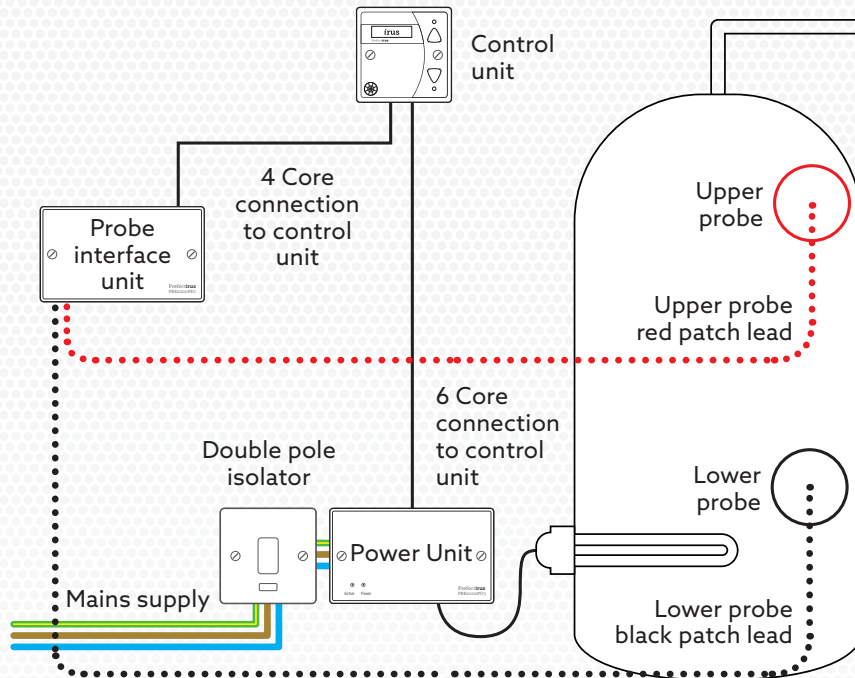

A double pole isolator is essential for isolating the ELEMENT, POWER UNIT, and CONTROL UNIT - for maintenance or replacement of components.

Throughout installation ensure all terminals are secure, but do not over-tighten.

INSTRUCTIONS

Wiring - Elements

(fig.1) The LIVE wire from the ELEMENT connects to the POWER UNIT'S LOAD terminal. The NEUTRAL and EARTH wires connect to the NEUTRAL and EARTH terminals on the POWER UNIT.

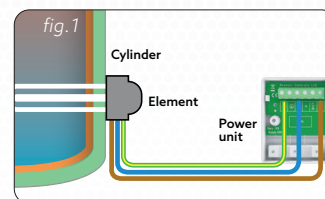

(fig.2) Use 3 core cable to connect the POWER UNIT to the ISOLATOR, taking the ISOLATOR LOAD LIVE to the LIVE on the POWER UNIT and the NEUTRAL and EARTH wires from the ISOLATOR LOAD to the NEUTRAL and EARTH terminals on the POWER UNIT.

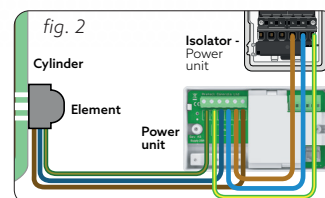

Due to our policy of continuous improvement, we reserve the right to change specifications without notice. All information was correct at time of when this product file was produced - April 2022

Preparing the tank (fig.3)

The tank needs to be prepared to accept the PROBES, this requires a 44mm Hole Saw, tape measure and a wire pencil brush.

(1) The TANK PROBES **must not** be fitted within 200mm of the nearest edge of an element.

(2) The centre of the probe should be level with the uppermost point of the element.

(3) The Upper and Lower probes should be vertically aligned.

(4) If the tank has a steel or plastic jacket use the hole saw to bore a 44mm hole. Be sure to only drill through the outer jacket. Stop when the outer jacket is cut.

ENSURE THE PILOT DRILL DOES NOT PIERCE THE INNER TANK SKIN.

Remove the pilot drill from the hole saw and then turn it by hand to gently cut through the insulation on the tank wall. Stop when you feel the teeth of the saw touch the metal side of the internal tank.

Remove and discard the insulation from the hole saw.

(5) Use a cleaning tool, such as a hand-held wire pencil brush, to remove any insulation residue left on the tank surface, ensuring it is clean.

Fitting the Probes

(6) Check the depth of the bore with the barrel of the PROBE.

If the barrel is too long and the flange isn't flush against the tank this can be sawn off to the bore depth. (fig.3/4)

The PROBE with the red label goes in the upper bore and black one in the lower bore. (fig.3)

The labels on the PROBES should be upright to ensure they are correctly positioned. The RJ45 cables should be able to hang down through the slot on the underside of the shaft.

Ensure the surface of the tank where the flange will adhere is cleaned thoroughly. Secure the PROBE mounting flange by removing the backing paper from the sticky pad, then press the flange flat against the tank surface. (fig.5)

If needed, use 4 self-tapping screws of appropriate length to provide the flange with additional fixing strength.

If the tank has a padded jacket use ratchet straps (*not supplied*) to hold the probes in place.

The THERMAL PASTE, in the supplied syringe, should be applied to the whole face of the copper head of the tank probes (approx 1mm depth) before they are inserted into the bores. (fig.6)

Insert the PROBE sensor through the upper mounting flange and push until the shaft will go no further, and the copper head is compressed into the shaft (fig.6).

Repeat this process with the lower sensor.

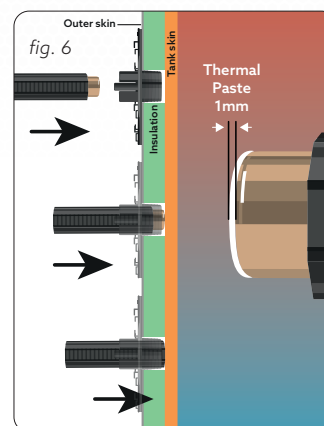
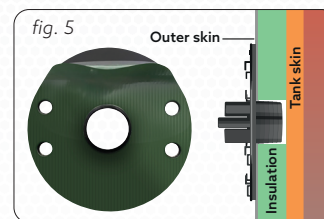
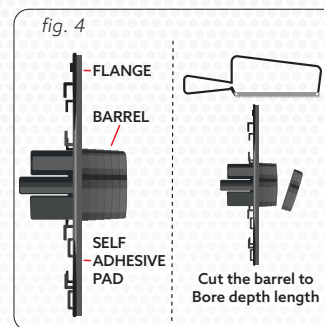
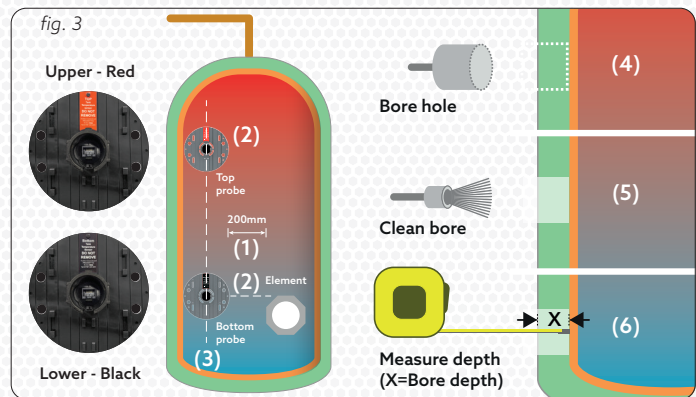

irus PRE2000W4



Cleverly simple
control of energy.

Instructions - page 4 of 4

Single element hot water tank control kit

Wiring - Control Unit

Use 6 core low voltage alarm cable to connect the CONTROL UNIT to the POWER UNIT ensuring the coloured wires going to the terminals match.

Do not use solid core data cable. The alarm cable length should not exceed 6 metres.

Wiring - Probe interface Unit

Use low voltage alarm cable to connect the CONTROL UNIT to the PROBE INTERFACE UNIT. Connect the EXT terminal on the PROBE INTERFACE UNIT to the EXT terminal on the CONTROL UNIT. Likewise, the THERM terminal on the PROBE INTERFACE UNIT is connected to THERM on the CONTROL UNIT.

Use the RED RJ45 patch lead to connect the UPPER PROBE to the PROBE INTERFACE UNIT and the BLACK RJ45 for the LOWER PROBE.

Set the top limit on the element's thermostat to 60°C.

Testing

The installation can be tested using the CONTROL UNIT.

WARNING -

ONLY TEST IF TANK IS FILLED WITH WATER.

Hold down the UP button and then press the DOWN button three times in quick succession. This puts the CONTROL UNIT into TEST MODE. Press the DOWN button one more time to enter TEST MODE L2.

This will turn the ELEMENT on. The screen will indicate Amps being drawn.

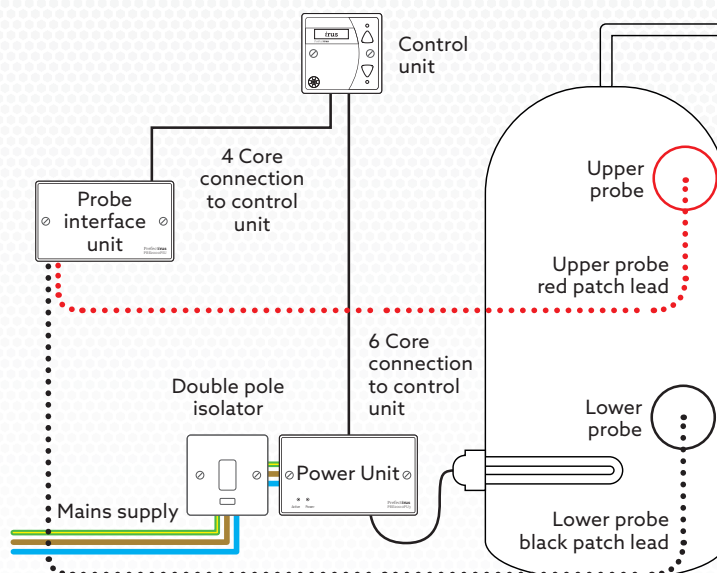
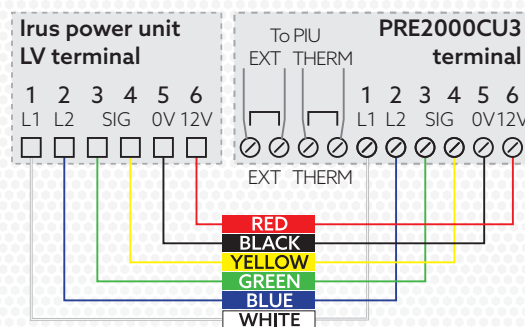

Our installation video can be viewed by scanning this QR code.

<https://prefectcontrols.com/prefect-irus-hot-water-control-installation-video-2/>



Due to our policy of continuous improvement, we reserve the right to change specifications without notice. All information was correct at time of when this product file was produced - April 2022

Prefect Controls Limited, Unit 2, Church Field Business Park, Church Field Road, Sudbury CO10 2YF
01787 320604 | mail@prefectcontrols.com | prefectcontrols.com