

PRE3204

Instructions - page 1 of 3

No neutral PIR detector



Cleverly simple
control of energy.

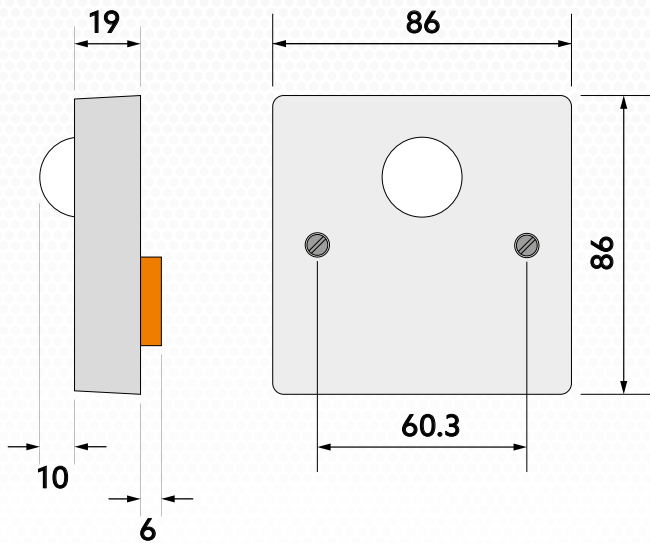

DESCRIPTION AND OPERATION

The PRE3204 PIR detector switches are designed to provide automatic control of lighting, heating or ventilation loads. They detect movement using a PIR sensor and turn the load on. When an area is no longer occupied the load will switch off after an adjustable time out period.

An optional internal light sensor provides additional energy saving in lighting applications. When an area is occupied lighting is only switched on when the level of natural light is below a preset level.

When the unit is first powered up the PIR sensor will always detect immediately regardless of whether the room is occupied. A selectable power up delay allows the installer to choose whether the load comes on immediately when the unit is powered up or is kept off for a small time (about 40 seconds) to allow the sensor to settle.

WIRING

To switch from more than one position simply wire two or more units in parallel to achieve two way and intermediate switching.

The detector should be sited so that the occupants of the room fall inside the detection pattern shown overleaf, at a recommended height of 1.2m to 1.5m for wall sensors. Note that the higher the sensor is installed the shorter the detection range will be.

- Avoid direct sunlight entering the sensor.
- Do not site within 1 m of forced air heating or ventilation.
- Do not site within 1 m of any lighting.
- Do not fix to a vibrating surface.

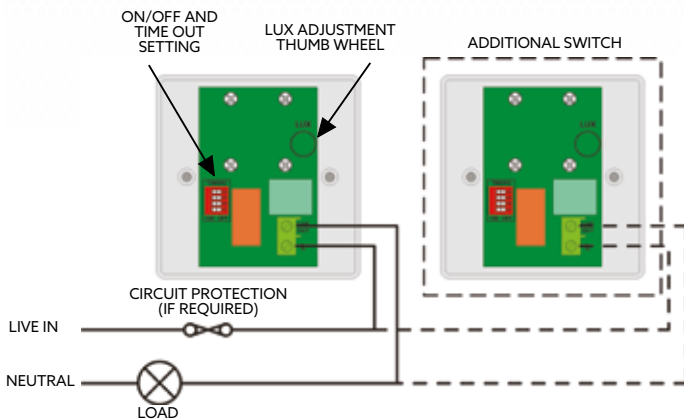

Due to our policy of continuous improvement, we reserve the right to change specifications without notice. All information was correct at time of when this product file was produced - April 2020



Cleverly simple
control of energy.

No neutral PIR detector

INSTALLATION

1. Make sure the load is connected and in working order.
2. Isolate the mains supply to the circuit at the main consumer unit.
3. Connect the controller via the terminal block. Live supply to the L terminal, Neutral to the N terminal and the load to the LIVE OUT terminal.
4. If fitted set the LUX level thumbwheel fully clockwise.
5. Set the time to minimum (fully anticlockwise) and set both switches to ON (0-1/2 hour range, no power up delay) according to the chart below.
6. Screw the unit to the wall and switch the mains supply back on at the distribution board.
7. The load should come on immediately.
8. Vacate the room or remain very still and wait for the load to switch off (should take no more than 2 minutes).
9. Check that the load switches on when movement is detected.
10. Now set the final LUX level and timing by isolating mains supply to the circuit at the main consumer unit.
11. To set the LUX level wait until the level of natural daylight is just enough that lighting is required. Starting with the LUX thumbwheel fully anticlockwise. Very slowly turn the thumbwheel clockwise until the lights come on. Note that when the LUX thumbwheel is fully clockwise then the lights will always come on with occupancy.
12. Select the time out range using the switch 1 according to the chart below. Set the time out period using the thumbwheel, fully clockwise is the maximum (either 1/2 hour or 1 hour depending on the range).
13. If required, select the power up delay (to prevent the load coming on immediately on power up).
14. Screw the unit to the wall and switch the mains supply back on at the distribution board.

WARNING! This device works at mains potential. Be sure to take care when working with electricity.

5 Minutes 10 Minutes 15 Minutes 20 Minutes 30 Minutes 40 Minutes 50 Minutes 60 Minutes

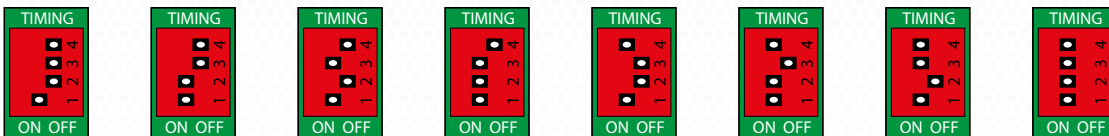

DETECTION PATTERN:

Detection Range 5-9 metres

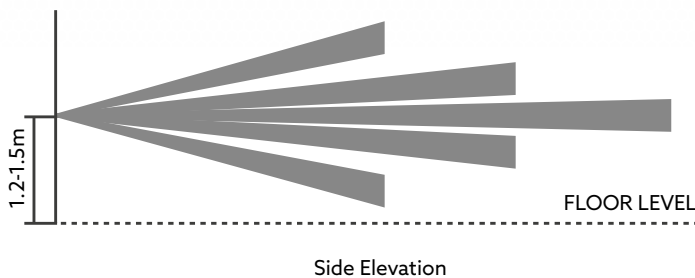

Detection Range 5-9 metres



Due to our policy of continuous improvement, we reserve the right to change specifications without notice. All information was correct at time of when this product file was produced - April 2020

PRE3204

Instructions - page 3 of 3

No neutral PIR detector



Cleverly simple
control of energy.

FAULT FINDING

Load does not come on:

For Check to see if the live supply to the circuit is good. Strap across the L and LIVE OUT terminal to turn the load on.

For LUX versions only, if the supply and wiring are good, check the LUX level setting. Increase the LUX level setting to allow the controller to turn on at higher ambient natural light level.

Lights do not go off

Ensure that the area is left unoccupied for a greater time period than the time out period set using the switch.

SPECIFICATION:

Load

16 Amp resistive load

10 Amp incandescent lighting

6 Amp fluorescent lighting

3 Amp compact fluorescent lighting

3 Amp low energy lighting

3 Amp low voltage lighting (switch primary of transformer)

Fluorescent lighting (max 6 fittings recommended)

For fluorescent lighting total power factor correction capacitance must not exceed 40 μ F.

3 Amp fans and ventilation equipment

Switch SON lighting loads via a contactor

Supply voltage

220-240 Volts AC 50 Hz

Time out period

Adjustable 10 seconds to 60 minutes in two ranges

Light level

Optional adjustment by thumbwheel light to dark.

Fixing method

Surface fixing 25mm deep plastic surface mount moulded box.
Flush fixing 25mm steel wall box or 32mm deep cavity wall box.

Terminal capacity

4.0mm²

Material

Flame retardant ABS

Type

Class 2

Temperature

-10°C to 35°C

Conformity

EMC-89/336/EEC
LVD-73/23/EEC

IMPORTANT NOTICE! This device should be installed by a qualified electrician in accordance with the latest edition of the IEE wiring regulations.