

PRE3203

Instructions - page 1 of 4

No neutral PIR switch



Cleverly simple
control of energy.



DESCRIPTION AND OPERATION

The PRE3203 presence detection switch replaces a standard single gang light switch. It detects movement using a PIR sensor and turns the lights on (either incandescent and fluorescent loads). An internal light sensor is provided for additional energy saving. When an area is occupied lighting is only switched on when the level of natural light is below a preset level. When an area is no longer occupied the lights will switch off after an adjustable time out period.

The PRE3203 incorporates a manual override facility for turning lights on and off by simply pressing the lamp symbol in the bottom right hand corner of the front plate. If the lights are on, using the override will turn the lights off permanently until the override is pressed again. If the lights are off (because of the ambient light) use the override to turn the lights on. The lights will remain on until the occupancy period is over.

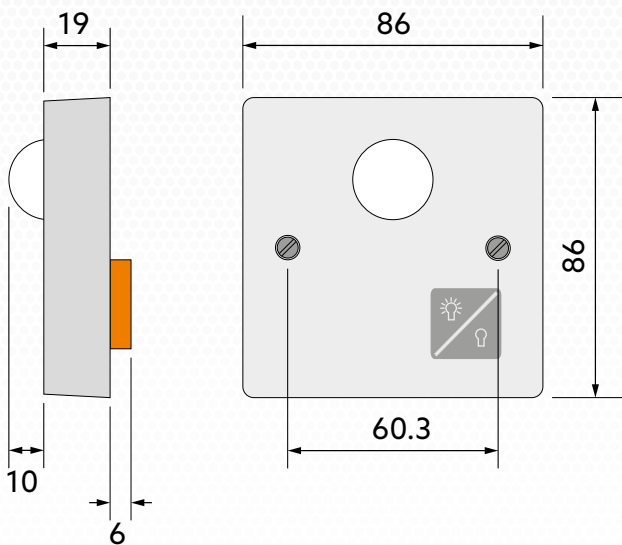

WIRING

Wire the PRE3203 as in the diagram below.

To switch from more than one position simply wire two or more units in parallel to achieve two-way and intermediate switching.

The detector should be sited at a recommended height of 1.2m to 1.5m so that occupants of the room fall inside the detection pattern shown overleaf. Note that the higher the sensor is installed the shorter the detection range will be.

- Avoid direct sunlight entering the sensor.
- Do not site within 1m of any lighting.
- Do not fix to a vibrating surface.

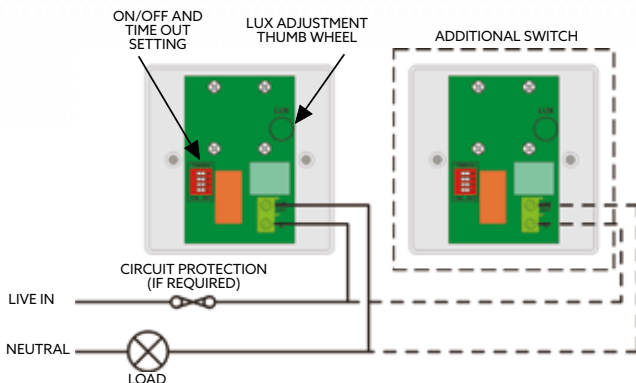

Due to our policy of continuous improvement, we reserve the right to change specifications without notice. All information was correct at time of when this product file was produced - April 2020



Cleverly simple
control of energy.

No neutral PIR switch

INSTALLATION

1. Make sure the load is connected and in working order.
2. Isolate the mains supply to the circuit at the main consumer unit.
3. Connect the controller via the terminal block. Live supply to the L terminal, and the load to the LIVE OUT terminal. **DO NOT SWITCH THE MAINS SUPPLY ON YET.**
4. Once the controller is connected, set the bottom switch position 1 to "ON" to power up the unit. A flashing LED should be visible through the detector lens. Once the LED is visible the internal battery is charged and you can proceed to step 6.
5. If the LED is not visible the battery requires charging. Change switch position 1 to "OFF", ensure the mains supply and load are connected, screw the unit to the wall, and switch the mains supply on. The unit should be left for 24 hours to fully charge, after which go back to step 4.
6. Set the LUX level thumbwheel fully clockwise, set the time out period required using the switches according to the chart above. Do this by moving switch positions 2, 3 & 4 only.
7. Screw the unit to the wall and switch the mains supply back on at the distribution board. The LED behind the detector lens should stop flashing after a few seconds. If it continues to flash there is either a) no load on the circuit, b) a problem with the wiring, or (c the light fitting needs a power factor correction capacitor) (see specification overleaf). Fix the problem, turn off switch 1 and start from step 4.
8. After approximately 5 seconds from power up the load will turn on and for the first 10 minutes of operating the controller has a fixed time out period of 10 seconds to aid setting the LUX level. After 10 minutes the time out reverts to the set value.
9. To set the LUX level, wait until the level of natural daylight is just enough that lighting is required. Starting with the LUX thumbwheel fully anticlockwise. Very slowly turn the thumbwheel clockwise until the lights come on. It is important that this is done during the first 10 minutes of power up. If you miss this then move switch 1 to OFF and then back to ON. Note that when the LUX thumbwheel is fully clockwise then the lights will always come on with occupancy.

WARNING! This device works at mains potential. Be sure to take care when working with electricity.

5 Minutes 10 Minutes 15 Minutes 20 Minutes 30 Minutes 40 Minutes 50 Minutes 60 Minutes

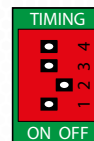
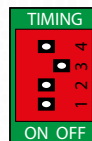
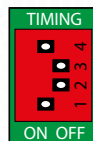
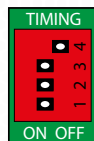
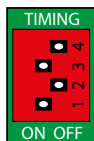
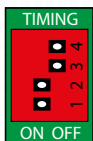
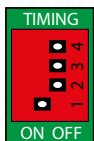



Cleverly simple
control of energy.

INSTALLING MULTIPLE SENSORS

1. When using multiple sensors to control the same load it is important that each sensor is installed and set up separately.
2. Follow the installation instructions on page 1 for the first sensor.
3. Disconnect either or both connections to the sensor (L or LIVE OUT) but do not change the switch settings.
4. Leaving the first sensor disconnected, connect the second sensor and start the installation procedure from step 1.
5. Leaving both the first and second sensor disconnected, start work on the third sensor etc. until all of the sensors are working.
6. Finally, re-connect all of the sensors.

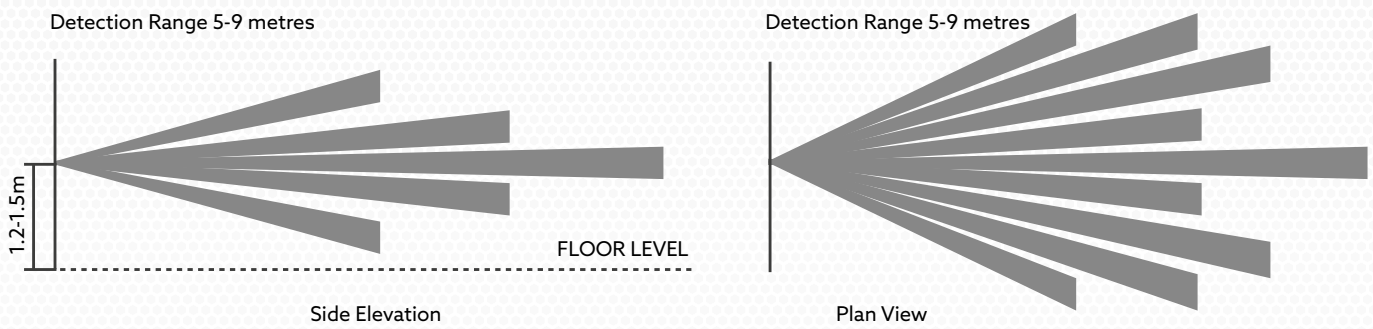

FAULT FINDING

Load does not come on:

For the PRE3203 model only, press the lamp symbol to ensure the controller has not been switched off manually.

Check to see if the live supply to the circuit is good. Strap across the L and LIVE OUT terminal to turn the load on.

If the supply and wiring are good, check the LUX level setting. Increase the LUX level setting to allow the controller to turn on at higher ambient natural light level.

If the load still fails to turn on follow step 5 of the installation instructions to recharge the internal battery.

Lights do not go off:

Ensure that the area is left unoccupied for a greater time period than the time out period set using the switch.

Make sure that the sensor is not adjacent to circulating air, heaters or lamps.

Lights flicker:

Ensure that there are sufficient power factor correction capacitors fitted.

PRE3203

Instructions - **page 4** of 4

No neutral PIR switch



Cleverly simple
control of energy.

SPECIFICATION

Load

10 Amp incandescent lighting
6 Amp fluorescent lighting
3 Amp compact fluorescent lighting
3 Amp low energy lighting
3 Amp low voltage lighting (switch primary of transformer)
Fluorescent lighting (max 6 fittings recommended)
Most fluorescent fittings have power factor correction capacitors fitted. If they are not present the unit may fail the installation procedure, in which case fit one capacitor per circuit with minimum value of 1 F for every PRE3202 installed.
Note that it is not necessary to fit a capacitor on every fitting.
For fluorescent lighting total power factor correction capacitance must not exceed 40 F.

Not suitable for switching contactors

Not suitable for SON lighting

Not suitable for heating or ventilation loads.

Please contact our sales department for a suitable alternative product.

Supply voltage	220-240 Volts AC 50 Hz
Time out period	Adjustable 5 minutes to 60 minutes by DIP switch.
Light level	Adjustable by thumbwheel light to dark.
Fixing method	Surface fixing 25mm deep plastic surface mount moulded box. Flush fixing 15mm steel wall box or 32mm deep cavity wall box.
Terminal capacity	1.5mm ²
Material	Polypropylene Flame retardant ABS
Type	Class 2
Temperature	-10°C to 35°C
Conformity	EMC-89/336/EEC LVD-73/23/EEC

IMPORTANT NOTICE!

This device should be installed by a qualified electrician in accordance with the latest edition of the IEE wiring regulations.