

PRE3201 - DD

Instructions - page 1 of 14

Ceiling mounted dimming PIR



Cleverly simple
control of energy.



DESCRIPTION AND OPERATION

The PRE3201-DD PIR (passive infrared) presence detector provides automatic control of lighting loads with optional manual control. Output Channel 1 comprises a mains voltage relay capable of simple On/Off switching, while Output Channel 2 provides dimmable control of either DALI or DSI type ballasts.

Functioning as a presence detector, the unit can turn lights on when a room is occupied and off when the room is empty. Optional settings allow lights to be turned off in response to ambient daylight, or to implement a maintained illuminance (daylight harvesting) system.

The flexibility of having two channels and two switch inputs allows the following example scenarios:

- Dim an outside row of luminaires whilst internal fittings are switched.
- Provide absence detection for two separate channels.
- Maintained illuminance system with manual up/down controls

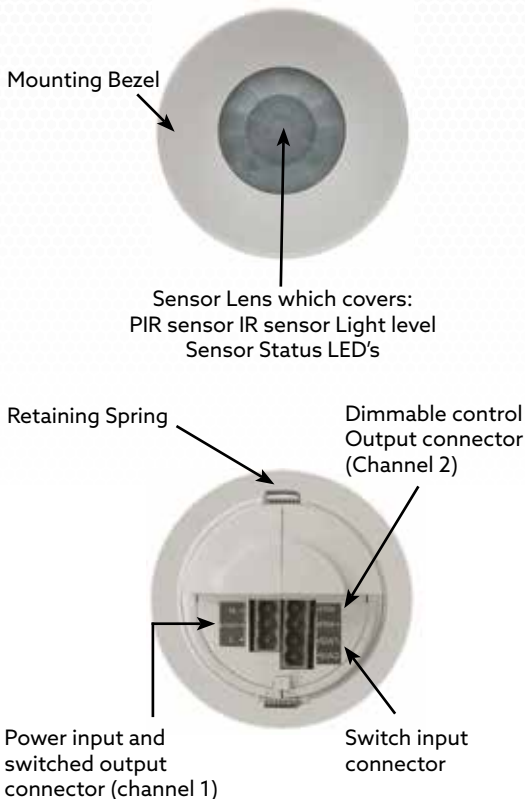

FEATURES

PIR Sensor - Detects movement within the unit's detection range, allowing load control in response to changes in occupancy.

IR Receiver - Receives control and programming commands from an IR (infrared) handset.

Light level sensor - Light level in the detection area.

Status LED's - The LED flashes red to indicate the following:

Walk Test LED active  when movement is detected

Valid setting received 

Power input & Switched output connector (channel 1) - Used to connect mains power to the unit and to connect a switched load.

Dimmable control output connector (Channel 2) - Used to connect DSI/DALI controllable ballasts and transformers for dimmable loads.

Switch input connector - Two input terminals can be used to manually override the dimming levels and override the lights on and off.

Due to our policy of continuous improvement, we reserve the right to change specifications without notice.
All information was correct at time of when this product file was produced - April 2020

PRE3201 - DD

Instructions - page 2 of 14

Ceiling mounted dimming PIR



Cleverly simple
control of energy.

DETECTION PATTERN

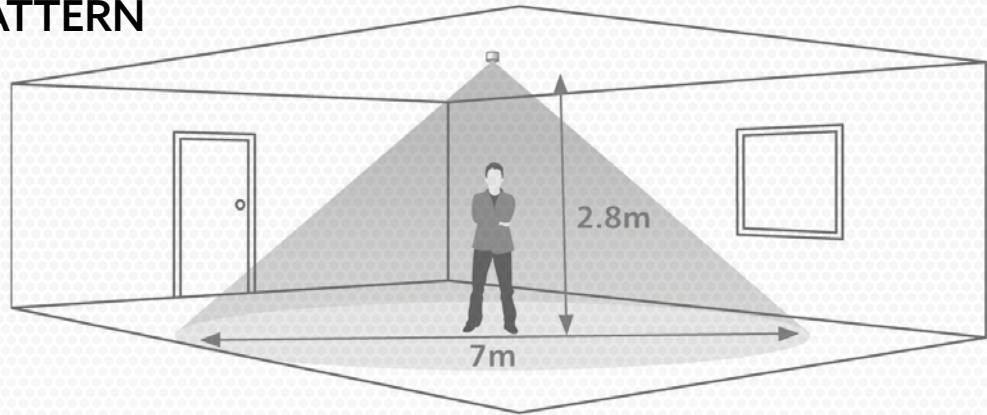

Area of high sensitivity

Area of lower sensitivity

UNIT DESCRIPTION

Choosing a suitable location. The PRE3201-DD is designed to be ceiling mounted and must satisfy the following criteria:

- Avoid positioning the unit where direct sunlight may enter the sensor element.
- Do not site the sensor within 1M of any lighting, forced air heating or ventilation.

SENSOR FUNCTIONALITY

Detection Mode. The Detection mode for both output channels 1 and 2 can be set to behave in presence or absence mode:

- Presence when movement is detected the load will automatically turn on. When the area is no longer occupied the load will automatically switch off after an adjustable time period.
- Absence the load is manually switched on. When the area is no longer occupied the load will automatically switch off after the adjustable time period has expired.

Switch Level On/Off. Occupancy detection can be made dependant on the ambient light level using the lux on level and lux off level parameters.

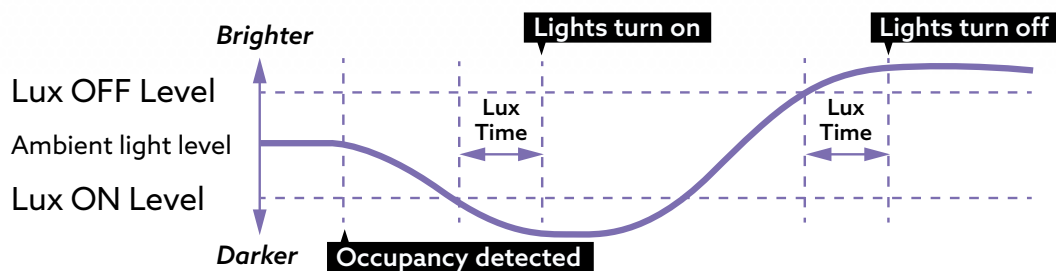

Maintained luminance (daylight Harvesting). The detector measures the overall light level on the detection area and calculates the correct output for the Luminaires, to achieve a preset lux level (maintained illuminance or daylight harvesting).

Due to our policy of continuous improvement, we reserve the right to change specifications without notice.
All information was correct at time of when this product file was produced - April 2020

PRE3201 - DD

Instructions - page 3 of 14

Ceiling mounted dimming PIR



Cleverly simple control of energy.

TEMPERATURE AND TIME SETTINGS

Overview

It's a requirement of many fluorescent lamp manufactures to have the lamps on at maximum output for a period of time to guarantee lamp life (refer to manufactures data sheet for details) As the PRE3201-DD is able to dim the lamps using DALI/DSI, the product provides a facility to disable this for a given period of time.

Operation by setting the "burn in" Parameter, you can select a time during which the lamps are not allowed to deviate from maximum output. The unit counts the time, and even remembers how long has elapsed in the event of a power failure. To cancel the burn in function, simply select a time of 0. Note that when the lamps are changed, the burn in time should be set again.

INSTALLATION

The PRE3201-DD is designed to be ceiling mounted:

• Flush fixing

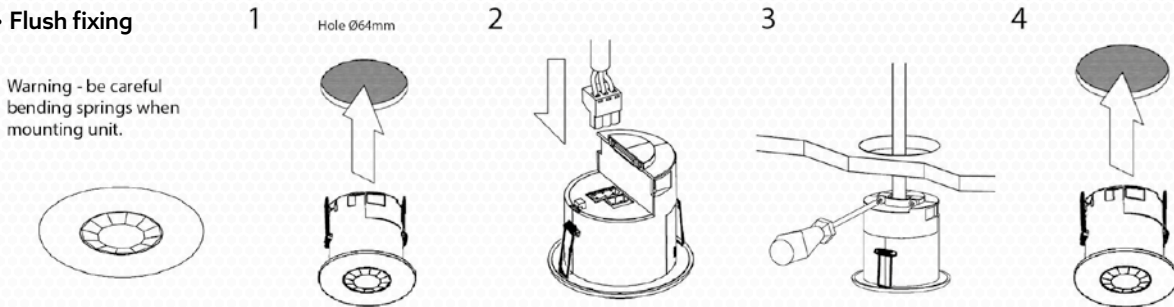

• Surface fixing, using the optional surface mounting box (part no. PRE3BB).

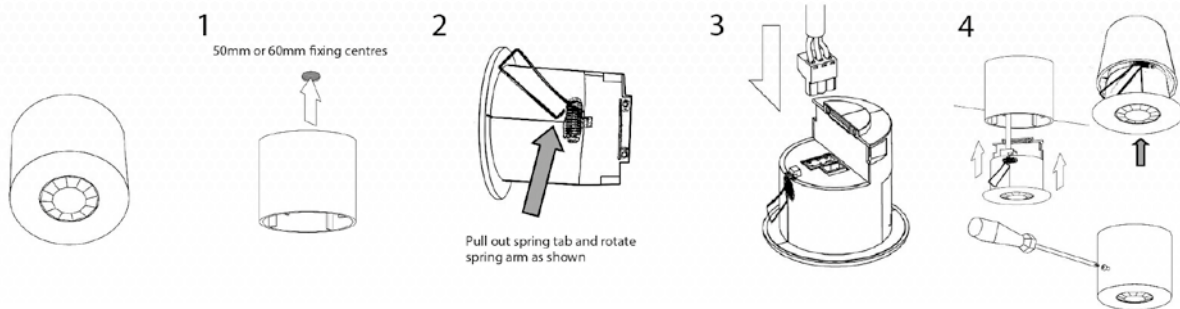

WIRE STRIPPING DETAILS

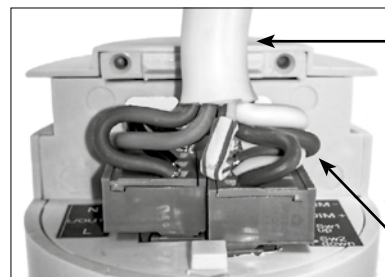
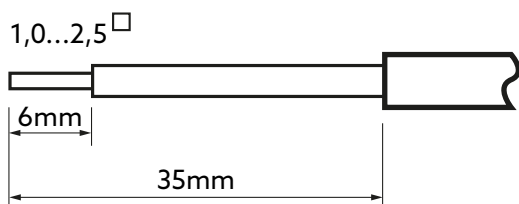

Important
Ensure that the cables are formed as shown before fixing the cable clamp. The clamp **MUST** clamp the outer sheath only.

Bend cores as shown

Due to our policy of continuous improvement, we reserve the right to change specifications without notice. All information was correct at time of when this product file was produced - April 2020



Cleverly simple
control of energy.

READ BACK FUNCTION (PRE5900L HANDSET ONLY)

The PRE5900 has the ability to read back the settings stored in a device.

To readback individual parameters

- Navigate to the parameter and press the "R" (Read) button whilst pointing the handset at the device. The handset will click when the parameter has been readback, the device will flash it's LED, and the value will be shown against the parameter in the menu.

To read back all of the parameters in a menu

- Press and hold the "R" (Read) Button for more than 1 second.
- The handset will click every time a parameter is received.
- The device will show multiple flashes of it's LED.
- All of the values will be shown against the parameters in the menu.
- The individual parameters may be edited and then saved as a "macro".

Notes

- If a parameter(s) has been missed because of a communication error, the missing value(s) is replaced by dashes.
- When reading back, the channel 1 relay (where fitted) will temporarily be switched of, and will return to it's normal state 2 seconds after the readback has been completed.

PRE3201 - DD

Instructions - page 5 of 14

Ceiling mounted dimming PIR



Cleverly simple
control of energy.

WIRING DIAGRAMS

Channel 1 (switched output) of the PRE3201-DD can either be used to switch a separate channel of standard, non-dimming luminaires, or to isolate the mains supply to dimming ballasts (saving on the standby current of the ballasts).

Multiple luminaires may be connected in parallel to channel 1 (via the N and L/OUT terminals) as long as the maximum total load is not exceeded.

Channel 2 (dimnable output) of the PRE3201-DD can be used to control light output of luminaires that are fitted with dimming ballast/transformers.

The ballasts/transformers can be connected in parallel to Channel 2 (via the Dim- and Dim+ terminals). refer to the specification on page 12 for ballast quantities.

The wiring examples below show common methods of connecting the output channels for a single detector unit.

SINGLE CHANNEL DIMMING

The PRE5900L has the ability to read back the settings stored in a device.

To readback individual parameters

- Navigate to the parameter and press the "R" (Read) button whilst pointing the handset at the device. The handset will click when the parameter has been readback, the device will flash it's LED, and the value will be shown against the parameter in the menu.

To read back all of the parameters in a menu

- Press and hold the "R" (Read) Button for more than 1 second.
- The handset will clock every time a parameter is received.

- The device will show multiple flashes of it's LED.
- All of the values will be shown against the parameters in the menu.
- The individual parameters may be edited and then saved as a "macro".

Notes

- If a parameter(s) has been missed because of a communication error, the missing value(s) is replaced by dashes.
- When reading back, the channel 1 relay (where fitted) will temporarily be switched off, and will return to it's normal state after 2 seconds after the readback has been completed.

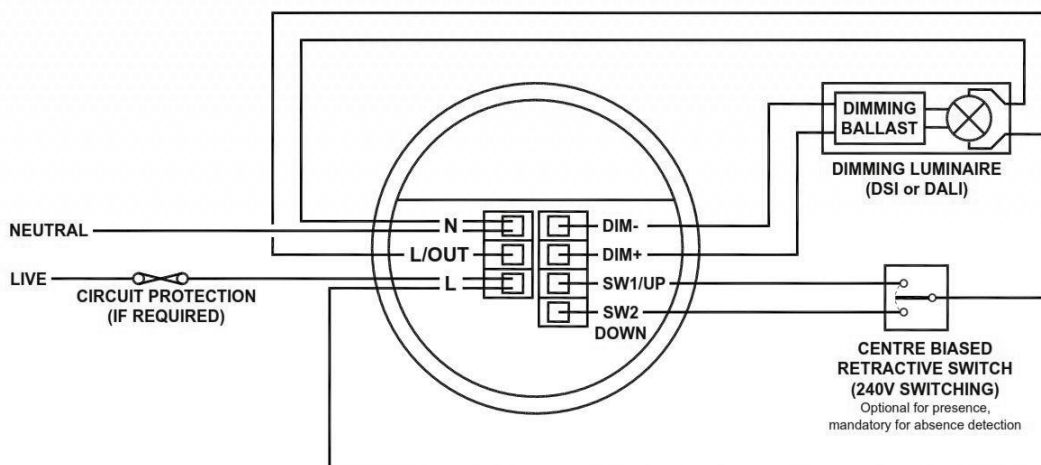

Due to our policy of continuous improvement, we reserve the right to change specifications without notice. All information was correct at time of when this product file was produced - April 2020

PRE3201 - DD

Instructions - page 6 of 14

Ceiling mounted dimming PIR



Cleverly simple
control of energy.

TWO CHANNEL INDIVIDUAL SWITCHES

Functions: switches both channels with occupancy. Maintains illuminance, dims and switches the dimming channel using optional single position retractive switch (switch 1).

Configured to presence detection: turns on automatically with occupancy. Maintains illuminance (dimming channel only). Press and release switch to toggle output. Press and hold switch to dim up and down (reverses direction with each press). Turns off after occupancy.

Configured to absence detection: Press and release switch to turn on. Maintains illuminance (dimming channel only). Press and Release switch to turn off. Press and hold switch to dim up and down (reverses direction with each press).turns off after occupancy.

Channel mode: Set to "switch and dim separate"

Switch mode: Set to "1 position switch separate"

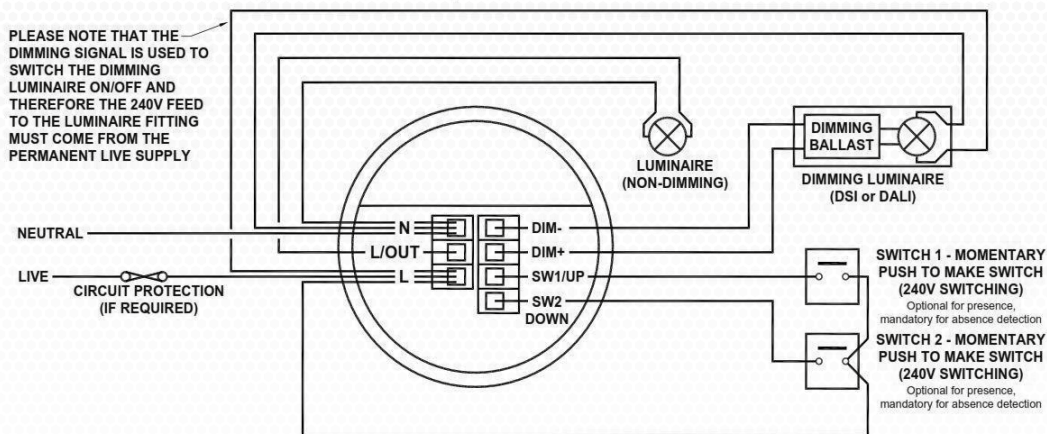

Due to our policy of continuous improvement, we reserve the right to change specifications without notice. All information was correct at time of when this product file was produced - April 2020

PRE3201 - DD

Instructions - page 7 of 14

Ceiling mounted dimming PIR



Cleverly simple
control of energy.

TWO CHANNEL SINGLE SWITCH

Functions: Switches both channels with occupancy. Maintains illuminance, dims and switches the dimming channel using optional center biased retractive switch.

Configured to presence detection: turns on automatically with occupancy. Maintains illuminance (dimming channel only). Press and release down switch to turn off. Press and release the up switch to turn back on. Press and hold up switch to dim up, press and hold the down switch to dim down. Turns off after occupancy. Channel 1 does not operate with switch.

Configured to absence detection: Press and release the up switch to turn on. Maintains illuminance (dimming channel only). Press and release the down switch to turn off. Press and hold the up switch to dim, press and hold the down switch to dim down. Turns off after occupancy. Channel 1 does not operate with switch.

Channel mode: Set to "switch and dim separate"

Switch mode: set to "2 position switch sperate"

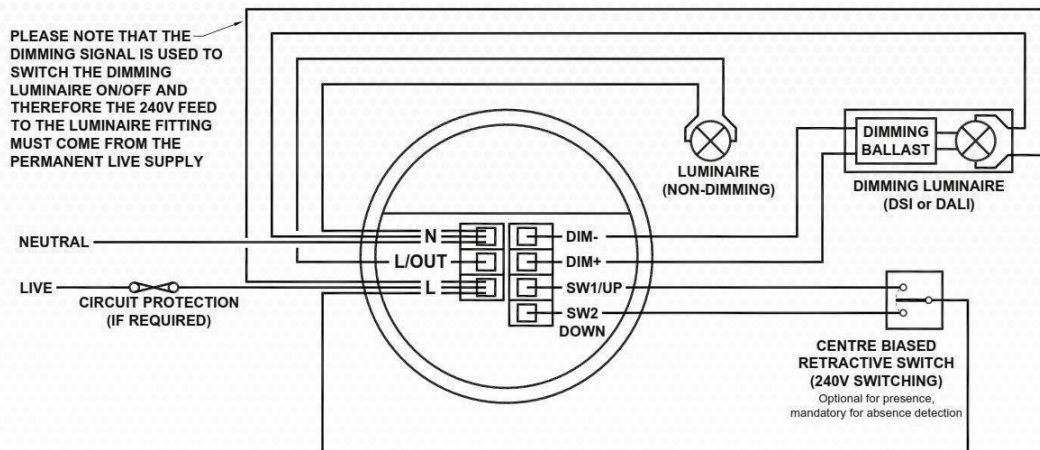

PLEASE NOTE THAT THE CENTRE BIASED RETRACTIVE SWITCH WILL PROVIDE CONTROL FOR THE DIMMING LUMINAIRE(S) ONLY. THE NON-DIMMING LUMINAIRE(S) WILL BE CONTROLLED ONLY BY THE SENSOR

Due to our policy of continuous improvement, we reserve the right to change specifications without notice. All information was correct at time of when this product file was produced - April 2020

PRE3201 - DD

Instructions - **page 8** of 14

Ceiling mounted dimming PIR



Cleverly simple
control of energy.

SINGLE CHANNEL SWITCHING

Functions: switches channel 1 only with occupancy, optional override switch. No dimming output.

Configured to presence detection: turns on automatically with occupancy. Press and release the down switch to turn off. Press and release the up switch to turn back on. Turns off after occupancy.

Configured to absence detection: Press and release up switch to turn on. Press and release down switch to turn off. Turns off after occupancy.

Channel mode: Set to "switch only"

Switch mode: Set to "2 Position switch together" note: a single position switch can be used instead to toggle the output, set to "1 position switch separate"

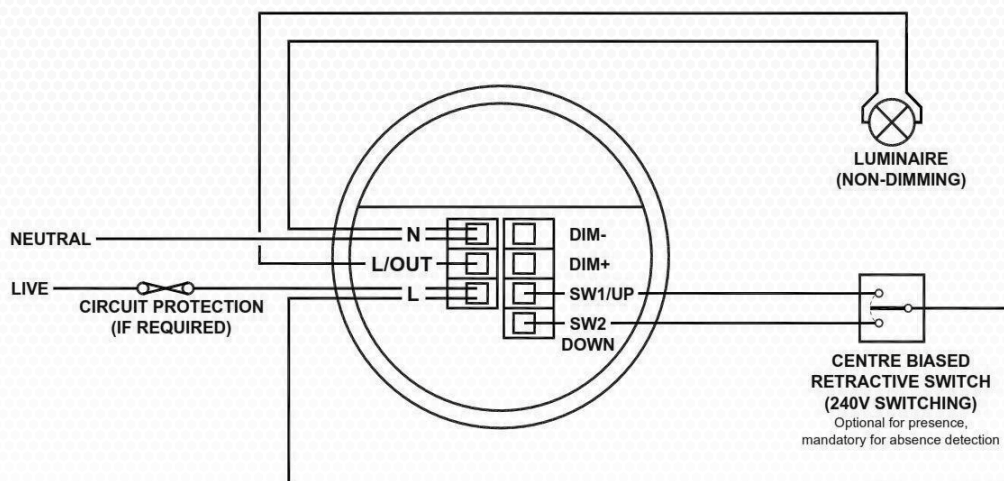

Due to our policy of continuous improvement, we reserve the right to change specifications without notice. All information was correct at time of when this product file was produced - April 2020

PRE3201 - DD

Instructions - page 9 of 14

Ceiling mounted dimming PIR



Cleverly simple
control of energy.

POWER-UP TEST PROCEDURE

When power is applied to the unit, the load will turn on immediately. Set the time out to 10 seconds and vacate the room or remain very still. Wait for the load to switch off. Check that the load switches on when movement is detected. The unit is now ready for programming.

FAULT FINDING

What if the load does not turn ON?

- Check that the live supply to the circuit is good.
- Check that the load is functioning by bypassing the sensor (e.g. link terminals L and L/OUT on channel 1).
- If the detection range is smaller than expected, check the diagram on page 2. Rotating the sensor slightly may improve the detection range.

Hint: The walk test LED function can be used to check that the unit is detecting movement in the required area.

What if the load does not turn off?

- Ensure that the area is left unoccupied for longer than the time out period.
- Ensure that the sensor is not adjacent to circulating air, heaters or lamps.

BASIC PROGRAMMING

The functionality of the PRE3201-DD is controlled by a number of parameters which can be changed or programmed by any of the following devices:

- **PRE5903** See next page for programming functions
- **PRE5900L** Infrared handset (with LCD). See user guide for full programming details.

For most basic programming operations the PRE5903 handset can be used. The following procedures are based on using this device.

Point the handset at the sensor and send the required programming commands to the unit as shown to the right.

Valid commands will be indicated by a red LED flash. See page 1 for details of other LED response.

Note: other functions on the PRE5903 which are not shown are not applicable to this product.



Due to our policy of continuous improvement, we reserve the right to change specifications without notice. All information was correct at time of when this product file was produced - April 2020

PRE3201 - DD

Instructions - page 10 of 14

Ceiling mounted dimming PIR



Cleverly simple control of energy.

Parameter name	Default value	Number of shift key presses				UHS5 Handset Graphics	Description
		0 Shift 1 Shift 2	1 Shift 1 Shift 2	2 Shift 1 Shift 2	3 Shift 1 Shift 2		
On/Raise		On	Raise				Turn lights on or to raise lights.
Off/Lower		Off	Lower				Turn lights off or to lower lights.
Walk test	Off	On	Off				When set to On, this causes a red LED to flash, on the sensor, when it detects movement. Use this feature to check for adequate sensitivity levels.
Time Out (Time adjustment)	20 minutes	1, 10 & 20 minutes	5, 15, & 30 minutes	10 seconds			Once the detector is turned on, this value sets how long the lights will stay on once movement has ceased.
Lux on level (Switch level on)	9	2, 5 & 7	4, 6 & 9				Lux level setting to prevent the luminaires being switched on if the ambient light level is sufficient (adjustable between 1 and 9). The luminaires will always be switched on at level 9.
Light level	6 (600)			2 (200) 5 (500) 7 (700)	4 (400) 6 (600) 9 (900)		Sets a target light level to be maintained by the lighting system.
Lux off level (Switch level off)	9	2, 5 & 7	4, 6 & 9				Lux level setting to switch the luminaires off during occupancy if the ambient light level goes above the setting (adjustable between 1 and 9). Level 9 will always keep the lights on. This setting can be used for "window row setting". *
Load type	DALI			2-DALI 7-DSI	2-DALI on		Sets the ballast control protocol to be used by the output channel.
Sensitivity	9	1, 5 & 9	3, 6 & 8				Sensitivity for detecting movement. 1 = low sensitivity 9 = high sensitivity.
Defaults				D			Returns the unit to the default settings.
Burn-in	0	0	50	100			Determines how long the output will be at 100% so that lamps 'burn-in'. The 'burn-in' time is not affected by power supply interruptions.
Presence/Absence	Presence	Presence	Absence				Presence mode allows the output to turn on when movement is detected and off when movement ceases. Absence mode allows the output to turn off when movement ceases, but must be manually turned on first.
Shift							Use this button to select the settings in red and blue signified by the 'Shift 1' and 'Shift 2' LEDs.

* NOTE: The Lux Off Level value must always be greater than the Lux On Level value.

Due to our policy of continuous improvement, we reserve the right to change specifications without notice. All information was correct at time of when this product file was produced - April 2020

PRE3201 - DD

Instructions - page 11 of 14

Ceiling mounted dimming PIR



Cleverly simple
control of energy.

ADVANCED PROGRAMMING

Parameter Name	Default Value	Range / Options	Description	UHS5	UNLCDHS
Detector Parameters					
Walk Test LED	Off	On or Off	When set to On this causes a red LED to flash, on the sensor, when it detects movement. Use this feature to check for adequate sensitivity levels.	✓	✓
Time Out (Time adjustment)	20 minutes	0-99 minutes	Once the detector is turned on, this value sets how long the lights will stay on once movement has ceased. Select 0 for 10 second delay - use for commissioning only.	✓	✓
Manual Time Out	10 minutes	0-99 minutes	When a manual operation occurs, either via the switch input or the infrared, it invokes the timeout period. Example 1: a detector in presence mode has a detector timeout of 15 minutes and a manual timeout of 3 minutes. When the user leaves the room they press the off button. The sensor will revert to automatic after 3 minutes, and then walking back in the room will turn the lights on. Example 2: using the settings above, the user turns the lights off (say for a presentation) but stays in the room. Every time a movement is detected, the manual timeout period is re-triggered, but when it doesn't pick up for the short timeout period, the sensor will timeout and revert to automatic. This means the lights may turn on inadvertently during the presentation, if the occupants are still for the manual timeout period, so adjust the timing carefully.	✗	✓
Sensitivity On	9	1 (min) to 9 (max)	Sensitivity level for detecting movement when the detector is already on. *UHS5 sets Sensitivity On and Off to the same value.	✓*	✓
Sensitivity Off	9	1 (min) to 9 (max)	Sensitivity level for detecting movement when the detector is off. *UHS5 sets Sensitivity On and Off to the same value .	✓*	✓
Lux time	0	0 (disabled) 1-99 minutes	If the detector measures the lux level and decides that the output needs switching on or off as a consequence, the lux time must elapse first. If at any time during the timed delay the lux change reverses then the process is cancelled. Lux Time enables absence detection to be implemented with a lux off level set. When the button is pressed, the lights will go on, regardless of ambient light level. However, if there is sufficient ambient light, they will turn off again after the Lux Time. Note that whenever an external switch is pressed, whether in absence or presence mode, if the lights were out because of the lux level, they will be immediately turn on again for at least the Lux Time.	✗	✓
Power Up State	On	On or Off	Select No for a 30 second delay on start up. If Yes is selected, there will be no delay on start up and the detector will always power up detecting.	✗	✓
Disable Detector	N	Y or N	Disables detection, leaving the relay output permanently off with the dimming output operational. This mode is used when the unit is for maintained illuminance only.	✗	✓
On Delay	0 minutes	0-99 minutes	The On Delay allows the first channel to switch on after the second channel. A typical application for this would be where a detector is controlling lighting and air conditioning in an area. When the occupant is detected, the lighting will be turned on immediately, whereas the air conditioning may be turned on after 15 minutes. If the area is vacated and the detector times out before the delay, then the air conditioning would never go on. The delay can be set only for channel 1 using the on delay parameter.	✗	✓
Inhibit	4 seconds	1 to 999 seconds	When the detector turns off, a delay is instigated to prevent retriggering. In certain circumstances this delay may not be enough. This parameter allows the delay to be changed.	✗	✓
Factory default	-	-	Restores factory default settings	✓	✓

Due to our policy of continuous improvement, we reserve the right to change specifications without notice. All information was correct at time of when this product file was produced - April 2020

PRE3201 - DD

Instructions - page 12 of 14

Ceiling mounted dimming PIR



Cleverly simple
control of energy.

Parameter Name	Default Value	Range / Options	Description	UHS5	UNLCDHS
Channel Modes					
Switch only	-	-	Usually used for absence detection - in this mode the dimming channel is not used.	✗	✓
Switch and dim together	Default	-	The detector will switch and dim the lighting together.	✗	✓
Switch and dim separate	-	-	Provides 2 channel operation - Channel 1 is switched via the relay output, and Channel 2 is dimmed/switched via the dimming output.	✗	✓
User Modes					
Raise	-	-	Increase light level. Reverts when occupancy cycle complete.	✓	✓
Lower	-	-	Decrease light level. Reverts when occupancy cycle complete.	✓	✓
Scene up	-	-	Steps up between 6 pre-defined scenes.	✗	✓
Scene down	-	-	Steps down between 6 pre-defined scenes.	✗	✓
Scene #	-	-	Select the individual scene, between 0 and 6. (1 = min. output; 2 = 10%; 3 = 25%; 4 = 50%; 5 = 75%; 6 = 100%)	✗	✓
Override On	-	-	If the lights are off, sending the IR command will turn them on immediately and revert to automatic operation using the manual timeout period.	✓	✓
Override Off	-	-	If the lights are on, sending the IR command will turn them off immediately. After the manual timeout period (described above), the sensor will revert to automatic.	✓	✓
Cancel	-	-	Cancels the on or off override, returning the detector to normal operation.	✗	✓
Switching Modes					
2 position switch together	Default	-	A single centre biased retractive switch will be used to control both channels together.	✗	✓
2 position switch separate	-	-	A single centre biased retractive switch will be used to control only the dimming channel.	✗	✓
1 position switch together	-	-	A single position retractive switch controls both channels together.	✗	✓
1 position switch separate	-	-	Two single position retractive switches, controlling the channels separately.	✗	✓
Channel 1 - Switching Channel					
Detection Mode	Presence	Presence or Absence	Presence mode allows the output to turn on when movement is detected and off when movement ceases. Absence mode allows the output to turn off when movement ceases, but must be manually turned on first.	✓	✓
Lux on level (Switch level on)	9	1-9 For a higher resolution a scale of 101-199 is available	Sets a minimum light level below which the PIR sensor is enabled, allowing lights to be turned on by movement. <i>Note: the Lux Level Off value must always be greater than the Lux Level On value.</i>	✓	✓
Lux on level (Switch level off)	9	1-9 For a higher resolution a scale of 101-199 is available	Sets a maximum light level above which the PIR sensor is disabled, preventing lights from being turned on by movement.	✓	✓

Due to our policy of continuous improvement, we reserve the right to change specifications without notice. All information was correct at time of when this product file was produced - April 2020

PRE3201 - DD

Instructions - page 13 of 14

Ceiling mounted dimming PIR



Cleverly simple
control of energy.

Parameter Name	Default Value	Range / Options	Description	UHSS	UNLCDHS
Channel 2 - Dimming Channel					
Detection Mode	Presence	Presence or Absence	Presence mode allows the output to turn on when movement is detected and off when movement ceases. Absence mode allows the output to turn off when movement ceases, but must be manually turned on first.	✓	✓
Lux on level (Switch level on)	9	1-9 For a higher resolution a scale of 101-199 is available	Sets a minimum light level below which the PIR sensor is enabled, allowing lights to be turned on by movement. <i>Note: the Lux Level Off value must always be greater than the Lux Level On value.</i>	✓	✓
Lux on level (Switch level off)	9	1-9 For a higher resolution a scale of 101-199 is available	Sets a maximum light level above which the PIR sensor is disabled, preventing lights from being turned on by movement.	✓	✓
Light Level (maintained illuminance)	600	1-998 (999 disabled)	Sets a target light level to be maintained by the lighting system.	✓	✓
Load Type	DALI	DSI DALI DALI On	Sets the ballast control protocol to DSI. Sets the ballast control protocol to DALI. DALI On provides a permanent voltage to DALI ballasts when DALI has not been implemented correctly in the ballast. Maximum number of ballasts is 5 unless the relay is disabled then it is 10.	✓ ✓ ✗	✓ ✓ ✓
Max Value	100%	0 to 100%	Maximum dimming output level.	✗	✓
Min Value	0%	0 to 100%	Minimum dimming output level.	✗	✓
Memorise	N	Yes or No	If this is set to Yes, the last manual lux level set will be memorised and used as the new switch on level.	✗	✓
On Value	99	0 to 99	Dimming output level when switched on (0-99).	✗	✓
Off Value	0	0 to 99	Dimming output level when switched off (0-99). If a non-zero off value is set, then the output will toggle between this value and completely off depending on the switch level on and off values. For example, if it is light outside, the fittings will be off if there is no occupancy. If it is dark outside, they will adopt the preset off value. This feature is only enabled if 'Min value' is set to 99.	✗	✓
Burn-in	0	0 (disabled) or 1 to 99 hours	Determines how long the output will be at 100% so that lamps 'burn-in'. The 'burn-in' time is not affected by power supply interruptions.	✓	✓
Fade Value	10	0 to 99	After occupancy ceases, this dimming output level is loaded for the fade time (adjustable between 0 and 99).	✗	✓
Fade mins	0	0 to 99	This is the time period (adjustable between 0 and 99 minutes) that the luminaire will be held at the fade value before turning off. A value of 0 disables the fade function.	✗	✓
Speed On	40	Measured in 0.1 sec intervals.	Determines the dimming response speed after the setup time has finished.	✗	✓
Speed Set	5	Measured in 0.1 sec intervals.	Determines the dimming response speed during the set up time. Measured in 0.1 sec intervals. If set to 0 will disable dimming for "Set seconds" below, used if fittings are required to warm up before dimming.	✗	✓
Speed Seconds	120	1 to 999 seconds	Determines how long the dimming response set-up period lasts on power-up or on setting change. This enables the desired lux level to be achieved rapidly when the lights come on, or during setup.	✗	✓

Due to our policy of continuous improvement, we reserve the right to change specifications without notice. All information was correct at time of when this product file was produced - April 2020

PRE3201 - DD

Instructions - page 14 of 14

Ceiling mounted dimming PIR



Cleverly simple
control of energy.

TECHNICAL DATA

Dimensions	See diagram opposite
Weight	0.15 KG
Supply Voltage	230VAC +/- 10%
Frequency	50Hz
Maximum Load	Channel 1 (switching)
Power consumption	On 625mW, Off 807mW
Dimming output	Basic insulation only. Although low voltage, this is not SELV output and should be treated as if mains potential. Use mains rated wiring.
Terminal Capacity	2.5mm ²
Temperature	- 10°C to 35°C
Humidity	5 to 95% non-condensing
Material (casing)	Flame retardant ABS and PC/ABS
Type	Class 2
IP rating	IP40
Compliance	EMC-2004/108/ECLVD-2006/95/EC

PRE3201-DD

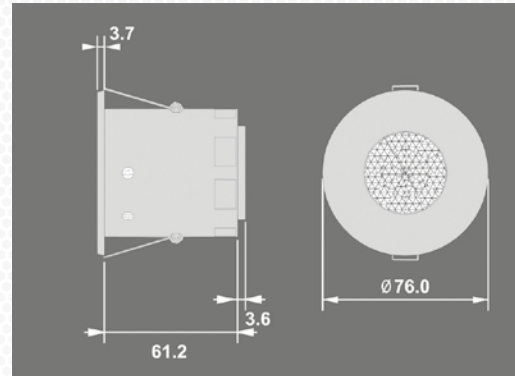

PRE3BB

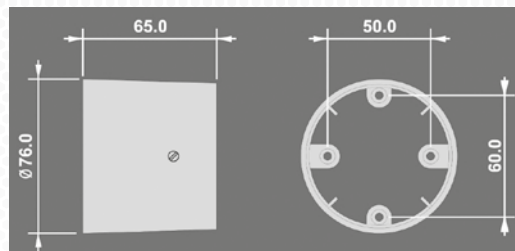

PART NUMBERS

	Part number	Description
Detector	PRE3201-DD	Ceiling PIR presence detector - DALI/DSI Dimming
Accessories	PRE3BB	Surface mounting box
	PRE5903	Programming IR handset
	PRE5900L	Universal LCD IR handset

IMPORTANT NOTICE

This device should be installed by a qualified electrician in accordance with the latest edition of the IEE Wiring Regulations and any applicable Building Regulations.



Due to our policy of continuous improvement, we reserve the right to change specifications without notice. All information was correct at time of when this product file was produced - April 2020

Prefect Controls Limited, Unit 2, Church Field Business Park, Church Field Road, Sudbury CO10 2YF
01787 320604 | mail@prefectcontrols.com | prefectcontrols.com