

# PRE9230

## Instructions - page 1 of 2

### Run timer



Cleverly simple  
control of energy.



## DESCRIPTION

The PRE9230 run back timer is a high output electronic timer which provides control for a wide range of loads. The unit allows an appliance to be powered for a set time period which can be adjusted by the user. A simple LED display shows the user how much time is left to run, and its "Night Light" feature illuminates all the LED's when the unit is not in use, so the unit can be located in the dark. Pressing the switch whilst the unit is operating allows the user to cancel the timing program, and the memory function of the timer will remember the last time period selected.

To operate the unit, follow these steps:

1. Press the button to start the timing sequence - the last selected time period will be used.
2. As the unit times out the position of the LED will change to show how much time is left. The LED will give a warning flash when 2 minutes are left on the timing sequence. Pressing the button again during timing will turn the unit off.
3. Press and hold the button to set the desired time period (15 minutes; 30 minutes; 1 hour or 2 hours). The LED will illuminate next to the selected time. After holding the button for a few seconds the timing will change to the next time period available. Release the button when it illuminates next to the desired time period - the LED will stay on the selected time.
4. When the unit has turned off, it is not necessary to select the time period again, just press the button to repeat the previous time period.

## INSTALLATION

**WARNING.** This device works at mains potential. Be sure to take care when working with electricity.

1. Make sure the load is connected and in working order.
2. If fitting to a metal back box ensure that top and bottom lugs are removed.
3. Isolate the mains supply to the circuit at the main consumer unit.
4. Connect the controller via the terminal block. Live supply to the L terminal, the load to the LIVE OUT terminal and neutral to the N terminal.
5. Screw the unit to the wall and switch the mains supply back on at the distribution board.

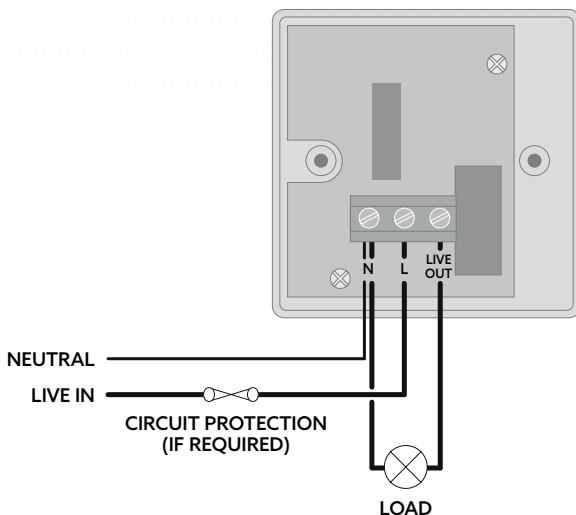
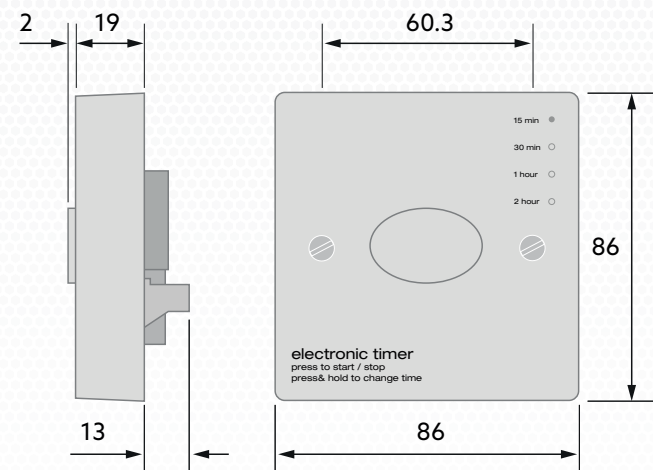

Due to our policy of continuous improvement, we reserve the right to change specifications without notice.  
All information was correct at time of when this product file was produced - April 2020

# PRE9230

## Instructions - page 2 of 2

### Run timer



Cleverly simple  
control of energy.

## SPECIFICATION

<b>Load</b>	16 Amp resistive load (including immersion heaters) 6 Amp fluorescent lighting. 3 Amp compact fluorescent lighting. 3 Amp low energy lighting. 3 Amp low voltage lighting (switch primary of transformer) Fluorescent lighting (max 6 fittings recommended)
<b>Supply voltage</b>	220-240 Volts AC 50 Hz
<b>Time out period</b>	15 minutes; 30 minutes; 1 hour or 2 hours (selectable)
<b>Fixing method</b>	Surface fixing 16mm deep plastic surface mount moulded box. Flush fixing 16mm deep steel wall box or 20mm deep cavity wall box.
<b>Terminal capacity</b>	4.0mm <sup>2</sup>
<b>Material</b>	Flame retardant ABS
<b>Type</b>	Class 2
<b>Temperature</b>	-10°C to 35°C
<b>Conformity</b>	EMC-89/336/EEC. LVD-73/23/EEC

**WE RECOMMEND THIS PRODUCT BE INSTALLED BY A COMPETENT PERSON IN ACCORDANCE WITH IEE REGULATIONS IN FORCE AT THE TIME.**

Due to our policy of continuous improvement, we reserve the right to change specifications without notice. All information was correct at time of when this product file was produced - April 2020