

# PRE9500

Instructions - **page 1** of 4

**Thermal drive valve**



Cleverly simple  
control of energy.



## SPECIFICATION

**Electrical specification** - 220-240VAC 50 Hz

**LOAD** - 2.5W

**Connections** - Live in, Neutral

**Running time for 3mm stroke** - Approx. 6 min.

**Positioning** - 90°-0°-90° off vertical

**Ambient temperature range** - -5° to 60°C

**Protection** - IP54

**Supplied lead length** - 900mm

**Operating time** - Closed to open: 3-6 minutes, open to closed 3-5 minutes. Times will vary depending on mains voltage, ambient temperature and connected valve spring force.

**Indicators** - Top cap rising indicator, The top cap of the PRE9500 will rise with the internal push rod indicating the current position of the radiator valve. Fully raised indicates the valve is fully open, fully lowered flush with the units chassis indicates the valve is closed.

Due to our policy of continuous improvement, we reserve the right to change specifications without notice.  
All information was correct at time of when this product file was produced - April 2020

**Prefect Controls Limited**, Unit 2, Church Field Business Park, Church Field Road, Sudbury CO10 2YF  
**01787 320604** | [mail@prefectcontrols.com](mailto:mail@prefectcontrols.com) | [prefectcontrols.com](http://prefectcontrols.com)

10134

# PRE9500

## Instructions - page 2 of 4

### Thermal drive valve



Cleverly simple  
control of energy.

## OPERATION

The PRE9500 wet radiator valve drive can be used with other Prefect control equipment to manage the flow of hot water through a wet radiator or valve, thus controlling the temperature in the room.

The PRE9500 has a common size mounting of 30mm X 1.5mm thread which can be used on a variety of different valve bodies. (Valve body not supplied.)

The PRE9500 is designed for silent operation so can be effectively used in offices, student bedrooms, schools & hotels.

The unit has an electrically heated, overrun-proof expansion element which transfers its stroke directly

to the valve. The unit is silent in operation and requires no maintenance.

When the heating element inside the unit is switched on, following a warming-up period of 3-6 minutes, the unit will complete a stroke of 3mm. The closing cycle will take from 3-5 minutes depending on conditions. The expansion element cools during this period and the valve is closed by spring pressure from inside the PRE9500.

Once fitted the unit may be locked in place to prevent removal by the occupant.

## TYPICAL WIRING LAYOUT

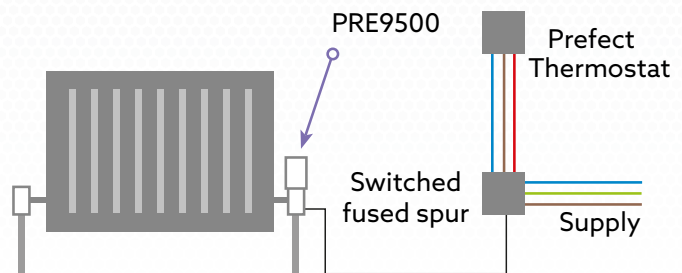
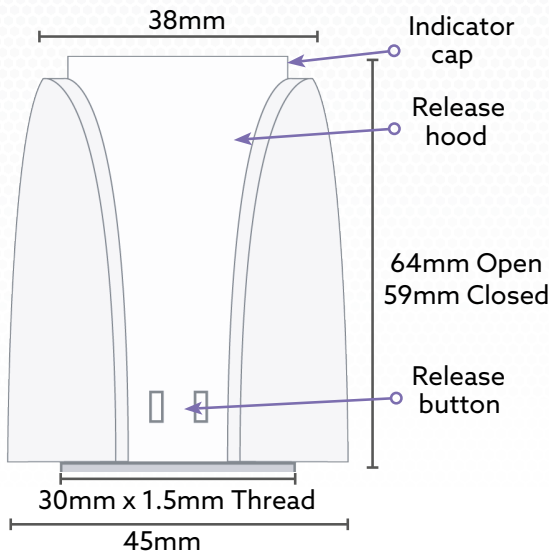

Due to our policy of continuous improvement, we reserve the right to change specifications without notice. All information was correct at time of when this product file was produced - April 2020

# PRE9500

## Instructions - page 3 of 4

### Thermal drive valve



Cleverly simple  
control of energy.

## FITTING

1. Fix the M30 fitting ring to the valve body.  
Do not over tighten the fitting ring, finger tight will be sufficient, the use of tools is not recommended for fitting.
2. Wire the unit as per the diagram on page 4.
3. Before fitting the PRE9500 to the locking ring, ensure the unit is fully powered and has run it's complete stroke to the fully open position, the full cycle is complete when the blue band is visible around the top cap. Do not fit the unit to the locking ring when the unit is closed as this may damage the fixings clips.
4. NOTE: The Spring pressure from the radiator valve pin reinforces the PRE9500 internal electrical connection. If prior to fitting the unit fails to open, apply pressure between the push rod and the top cap as per the diagram below while the unit is powered. Continue to apply pressure until the unit is fully open. Thumb and forefinger will provide sufficient force, do not use any type of tooling on the unit.
5. Once the PRE9500 is fully open, align the PRE9500 with the locking ring and push downward keeping the unit square until the fixing clips spring into place.
6. If the valve is required to be locked securely in place, remove the transparent front hood by pulling the top left or right corner of the hood and disengaging the pivot pins.

Firmly press the top cap and push rod together. Continue to apply pressure until the unit has completed it's full travel to the open position.

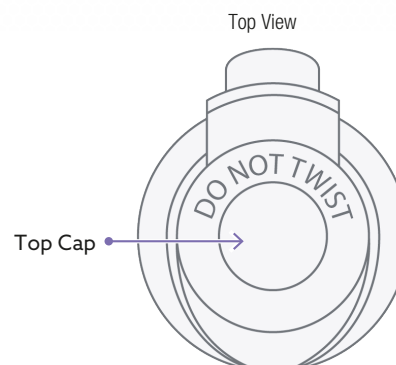
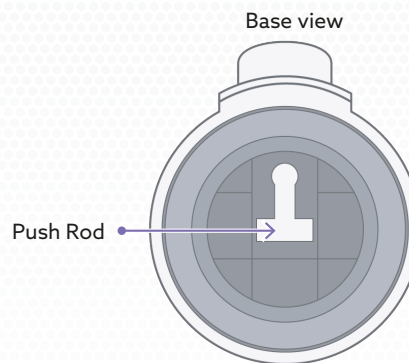
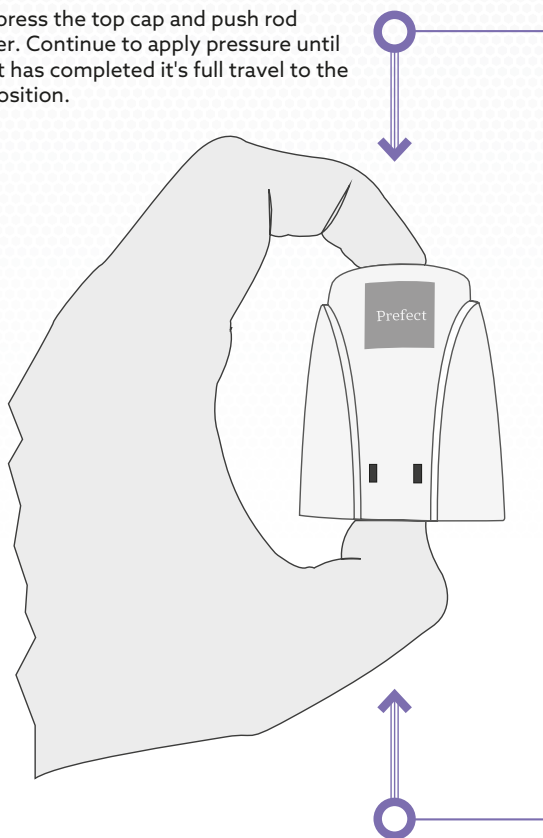

Due to our policy of continuous improvement, we reserve the right to change specifications without notice.  
All information was correct at time of when this product file was produced - April 2020

# PRE9500

## Instructions - page 4 of 4

### Thermal drive valve



Cleverly simple  
control of energy.

## REMOVAL

1. To remove the PRE9500 from the locking ring, firmly press the release button and gently pull the unit upwards. The unit may be removed powered or non-powered, It is however recommended to remove the unit while in the open position.
2. If the hood has been removed, locate the top left and right hand pivot pins into the pin holes in the unit body. Once the hood is fitted follow step 1.
3. The PRE9500 cannot be removed without damage if the hood is not utilized for removal.

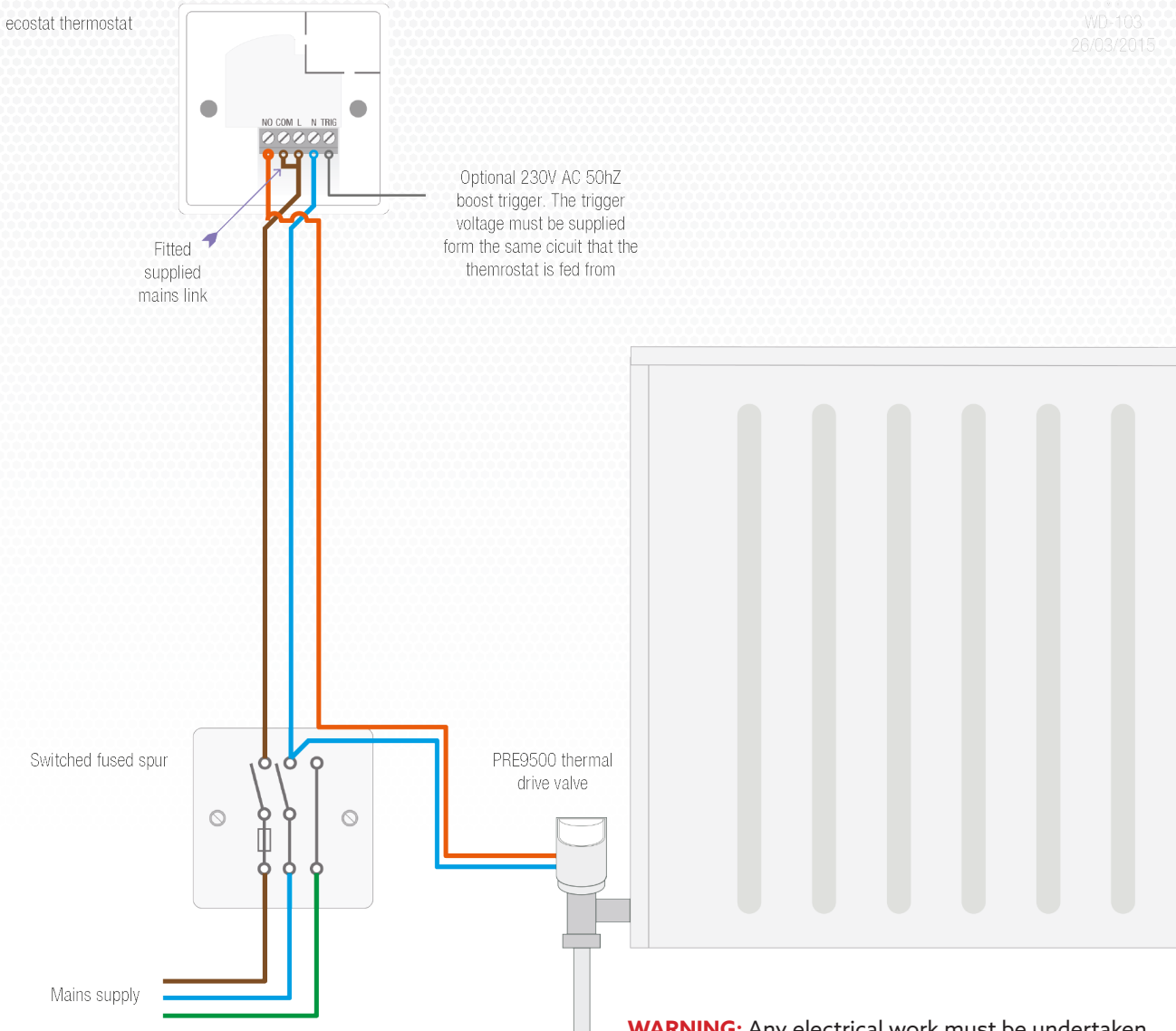

**WARNING:** Any electrical work must be undertaken by a competent person or persons in line with the regulations in force at the time of fitting.

Due to our policy of continuous improvement, we reserve the right to change specifications without notice. All information was correct at time of when this product file was produced - April 2020