

Touch Auto-on 3 stage infra-red settable intelligent thermostat with 7 day auto-on feature.

Cleverly simple control of energy.



SPECIFICATION

Size

Size: Standard single gang plate size. Requires a 30mm deep surface pattress or 25mm or greater sunken box. When mounting into a sunken wall box or metal clad box remove the top and bottom mounting lugs of the box.

Supply voltage

216-253V AC at 50Hz.

Load

16A Resistive, not suitable for use with quartz heaters.

Electrical connections

Live in (Lin), Neutral (Nin), Common (COM), Normally open/live out (Lout), 216-253V AC 50Hz Boost Trigger (TRIG).

Terminal capacity

6mm² Maximum cable CSA, internal terminal size 2.9mm x 4mm.

Indicators

Heating active, Frost, Boost.

Adjustment

Frost or boost selection, button selected.

Programs

Boost, Setback, Frost.

Timing range

Boost 0-999 minutes, Setback 0 minutes to 999 hours.

Temperature range

Boost, Setback and Frost 1 to 40°C.

Clock events

Two auto-on events per day, 7 day programmable.

Clock range

23 hours, 59 minutes

Clock cell

CR2477 3V, Available from Prefect using code PRE5001B (not supplied)

Clock cell life expectancy

Based upon 2 months per year the unit is powered down, 5 Years.

Programming method

AUTO LOCK SYSTEM © Secure infra-red programming via the PRE5901 handset.

Conformance

EMC-2004/108/EC LVD-2006/95/EC

ERP Class

ErP Class 1, SHE 1%

ERP seasonal heating efficiency

1%

Casing material

PC/ABS

Temperature Range

0°C to 40°C

Temperature accuracy

+/- 0.5°C

IP Rating

IP3X

Ecodesign Lot 20 compliant

Yes

Warranty

5 Years

Due to our policy of continuous improvement, we reserve the right to change specifications without notice. All information was correct at time of when this product file was produced - April 2020



Touch Auto-on 3 stage infra-red settable intelligent thermostat with 7 day auto-on feature.

INDEX

INSTALLATION

What is the thermostats specification?	Page 1
Where and how do I mount the thermostat?	Page 3-4
How do I install the thermostat with an electric panel heater?	Page 5
How do I activate an Atlantic Energy Lock heater?	Page 6
How do I install the thermostat with a wet radiator?	Page 7
How do I install the thermostat with a volt free contact boiler?	Page 8
How do I install the thermostat with a mains boiler?	Page 9
How do I Troubleshoot the thermostat?	Page 10/11

PROGRAMMING

What do the LEDs mean?	Page 12
What does boost, setback and frost mean?	Page 12
How does the occupant adjust the thermostat?	Page 12
How does the live boost trigger work?	Page 13
How does the clock function work?	Page 13
How does optistart work?	Page 13
How do programs work?	Page 14, 15
Special Functions	Page 16
How does the window open detection work?	Page 16

SETTINGS AND SETUP

What do the settings mean?	Page 19/20
How do I set the thermostat?	- See PRE5901 Instruction manual: IN-127 PRE5901

SERVICE

How do I install the battery?	Page 21
Frequently asked questions	Page 22

Touch Auto-on 3 stage infra-red settable intelligent thermostat with 7 day auto-on feature.

INSTALLATION

- All installation and wiring works must be completed by a competent person and conform to relevant regulations in force at time of installation.
- Locate the thermostat at least 300mm away from the nearest edge of the heater. Ensure the thermostat is placed where it cannot be affected by extraneous heat sources, for example: televisions, desktop computers, fridges. If fitted too close to an extraneous heat source the thermostat will not function correctly. Do not mount the thermostat above a heater or radiator. Mount the thermostat at the centre point of the room if possible. Do not mount the thermostat behind curtains or room dividers.
- Ensure the thermostat has a local means of safe isolation. A double pole isolator must be used. A PRE6000 double pole key switch is recommended.
- Mount the thermostat between 1.2m and 1.4m from finished floor level.
- The thermostat can be mounted in both surface and sunken boxes. When mounting into a metal clad pattress or sunken box the upper and lower box lugs must be removed.
- Ensure the thermostat is not mounted within 1m of forced heating or ventilation systems.
- Ensure the thermostat is not in a position to be covered or isolated from the room environment. Do not mount directly next to a window.
- Ensure the thermostat is easily accessible and does not put occupants or service engineers at risk of injury.

TYPICAL ELECTRICAL LAYOUT - Not to scale

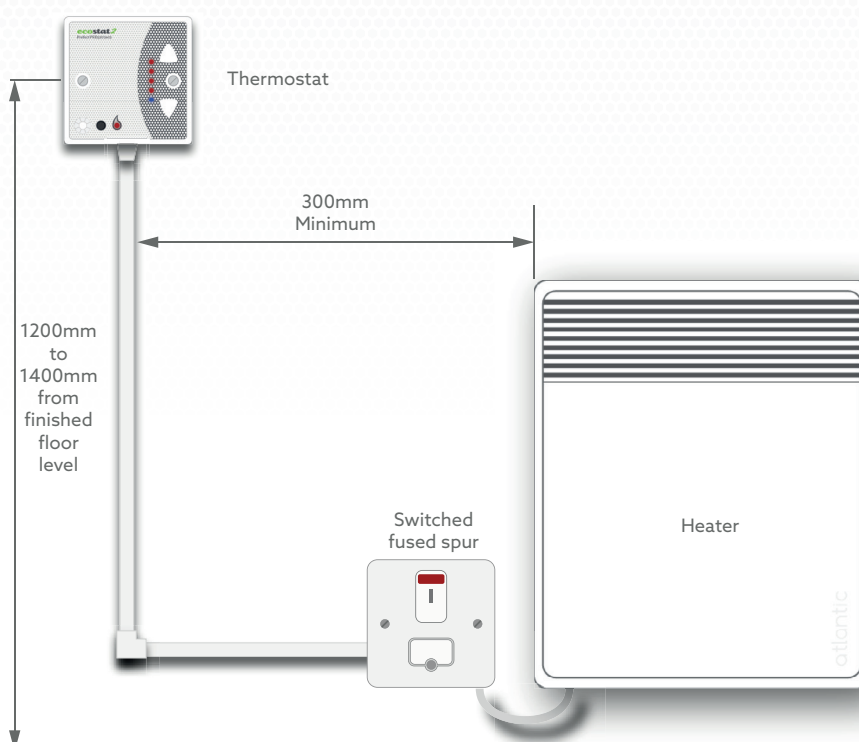

Due to our policy of continuous improvement, we reserve the right to change specifications without notice. All information was correct at time of when this product file was produced - April 2020

Touch Auto-on 3 stage infra-red settable intelligent thermostat with 7 day auto-on feature.

INSTALLATION

- All installation and wiring works must be completed by a competent person and conform to relevant regulations in force at time of installation.
- Locate the thermostat at least 300mm away from the nearest edge of the radiator. Ensure the thermostat is placed where it cannot be affected by extraneous heat sources, for example: televisions, desktop computers, fridges. If fitted too close to an extraneous heat source the thermostat will not function correctly. Do not mount the thermostat above a heater or radiator. Mount the thermostat at the centre point of the room if possible. Do not mount the thermostat behind curtains or room dividers.
- Ensure the thermostat has a local means of safe isolation. A double pole isolator must be used. A PRE6000 double pole key switch is recommended.
- Mount the thermostat between 1.2m and 1.4m from finished floor level.
- The thermostat can be mounted in both surface and sunken boxes. When mounting into a metal clad pattress or sunken box the upper and lower box lugs must be removed.
- Ensure the thermostat is not mounted within 1m of forced heating or ventilation systems.
- Ensure the thermostat is not in a position to be covered or isolated from the room environment. Do not mount directly next to a window.
- Ensure the thermostat is easily accessible and does not put occupants or service engineers at risk of injury.

TYPICAL WET LAYOUT - Not to scale

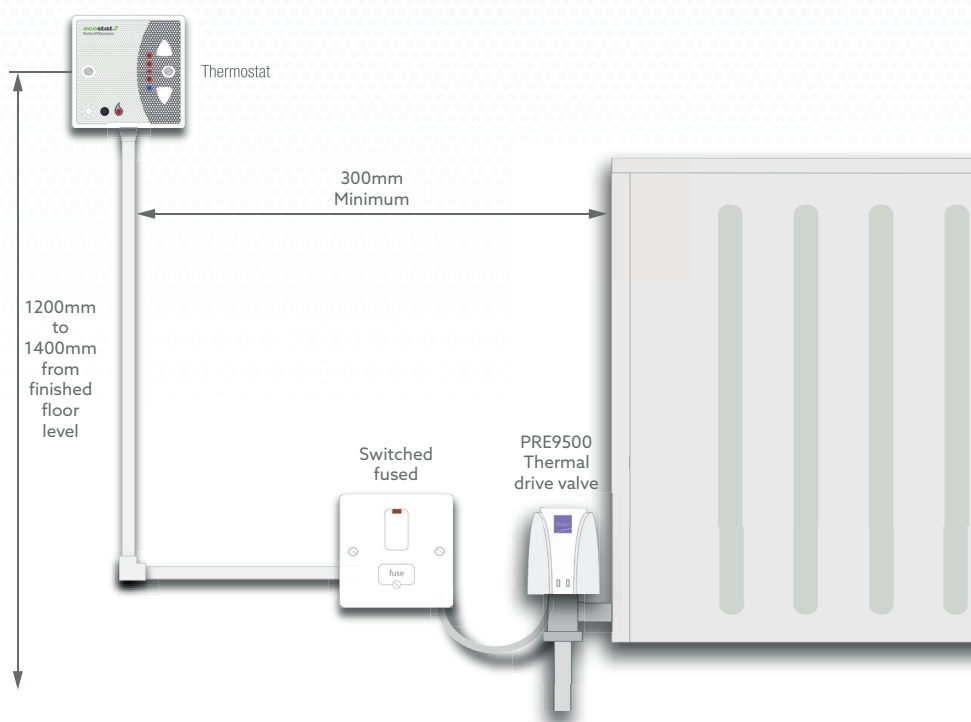

Due to our policy of continuous improvement, we reserve the right to change specifications without notice. All information was correct at time of when this product file was produced - April 2020

Touch Auto-on 3 stage infra-red settable intelligent thermostat with 7 day auto-on feature.

Cleverly simple control of energy.

WIRING

MAINS OUTPUT

1. All wiring works should be completed by a competent person/s. Isolate the appropriate circuit that the thermostat is to be supplied from. Perform safe isolation procedure to ensure the circuit is completely isolated. Ensure the supply has been locked in the off position. Always ensure safe working practices.
2. Make any circuit adjustments required in accordance with current regulations.
3. If the trigger terminal is to be used ensure the trigger supply is fed from the same circuit as the thermostat supply to conform with current regulations.
4. Connect the live and neutral supply to the thermostat, note that the load neutral must be fitted with the supply neutral. Ensure the supplied mains link is fitted between Lin and COM terminals, terminate the loads live supply to the normally open terminal (Lout). Ensure the link is securely fastened in both the Lin and COM terminals.
5. Recheck all terminals including any factory fitted connections then fit the unit to the back box ensuring cables are not in a position to be damaged.
6. Re-energise the circuit. Press the up button twice to enable a 2 minute test cycle.

VOLT FREE OUTPUT

1. All wiring works should be completed by a competent person/s. Isolate the appropriate circuit that the thermostat is to be supplied from. Perform safe isolation procedure to ensure the circuit is completely isolated. Ensure the supply has been locked in the off position. Always ensure safe working practices.
2. Make any circuit adjustments required in accordance with current regulations.
3. If the trigger terminal is to be used ensure the trigger supply is fed from the same circuit as the thermostat supply to conform with current regulations.
4. Terminate the live and neutral supply to the thermostat. Ensure the supplied mains link is removed.
5. Terminate the loads feed cable to the common (COM) terminal. Terminate the load return to normally open terminal (Lout).
6. Recheck all terminal connections and fit the unit to the back box ensuring cables are not in a position to be damaged.
7. Re-energise the circuit. Press the up button twice to enable a 2 minute test cycle.

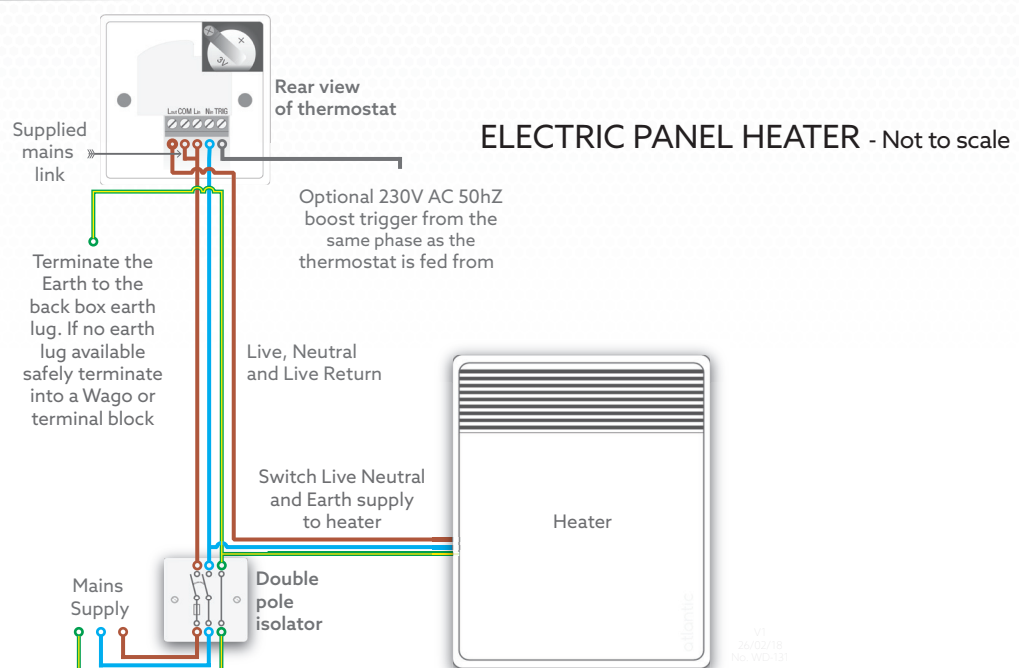

Due to our policy of continuous improvement, we reserve the right to change specifications without notice. All information was correct at time of when this product file was produced - April 2020

Touch Auto-on 3 stage infra-red settable intelligent thermostat with 7 day auto-on feature.



Cleverly simple
control of energy.

ATLANTIC HEATERS WITH ENERGY LOCK



When using an Atlantic panel heater with Prefect Energy Lock, a key (Fig 6) needs to be installed before the heater can be used.

- Holding the key with the tooth at the top, note the T shape of the tooth. On the top right hand side of the heater is a plastic cover, on this cover you will see a corresponding T slot. Locate the key into the T slot on the heater (see fig 7).
- Once the key is located into the T slot, push the key home until it is flush (see fig 8). Once the key is fitted the heater will be able to operate when the thermostat is calling for heat.

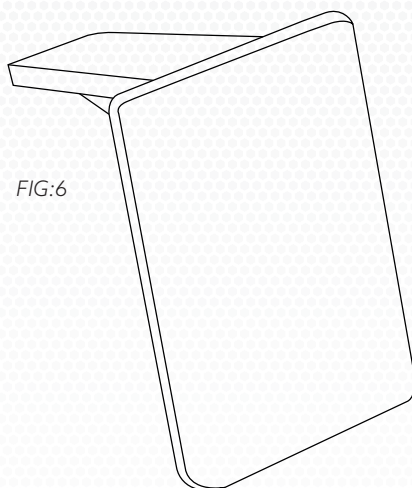

FIG:6

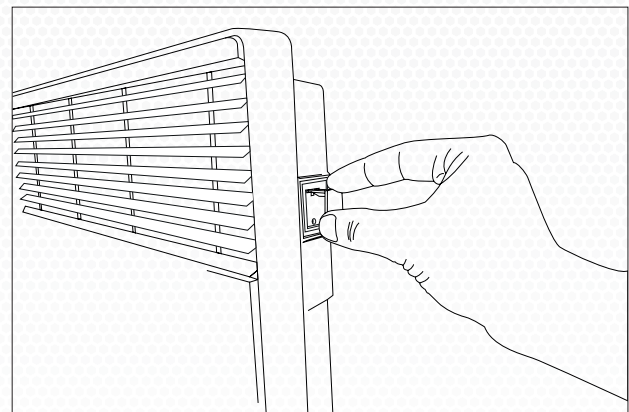

FIG:7

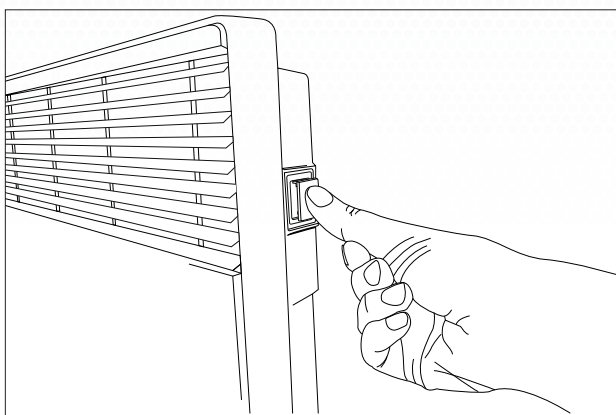

FIG:8

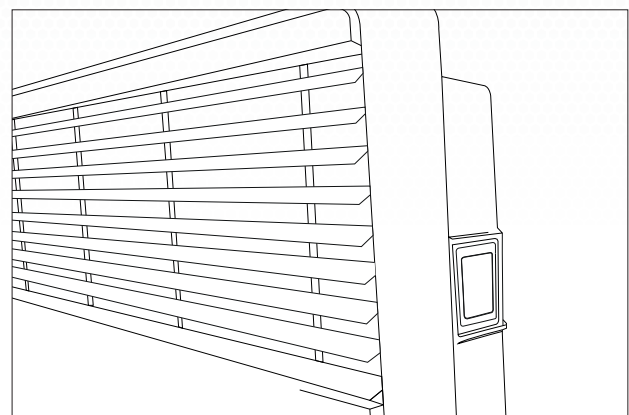

FIG:9

Due to our policy of continuous improvement, we reserve the right to change specifications without notice. All information was correct at time of when this product file was produced - April 2020

Touch Auto-on 3 stage infra-red settable intelligent thermostat with 7 day auto-on feature.

Cleverly simple control of energy.

WET RADIATOR & VALVE DRIVE

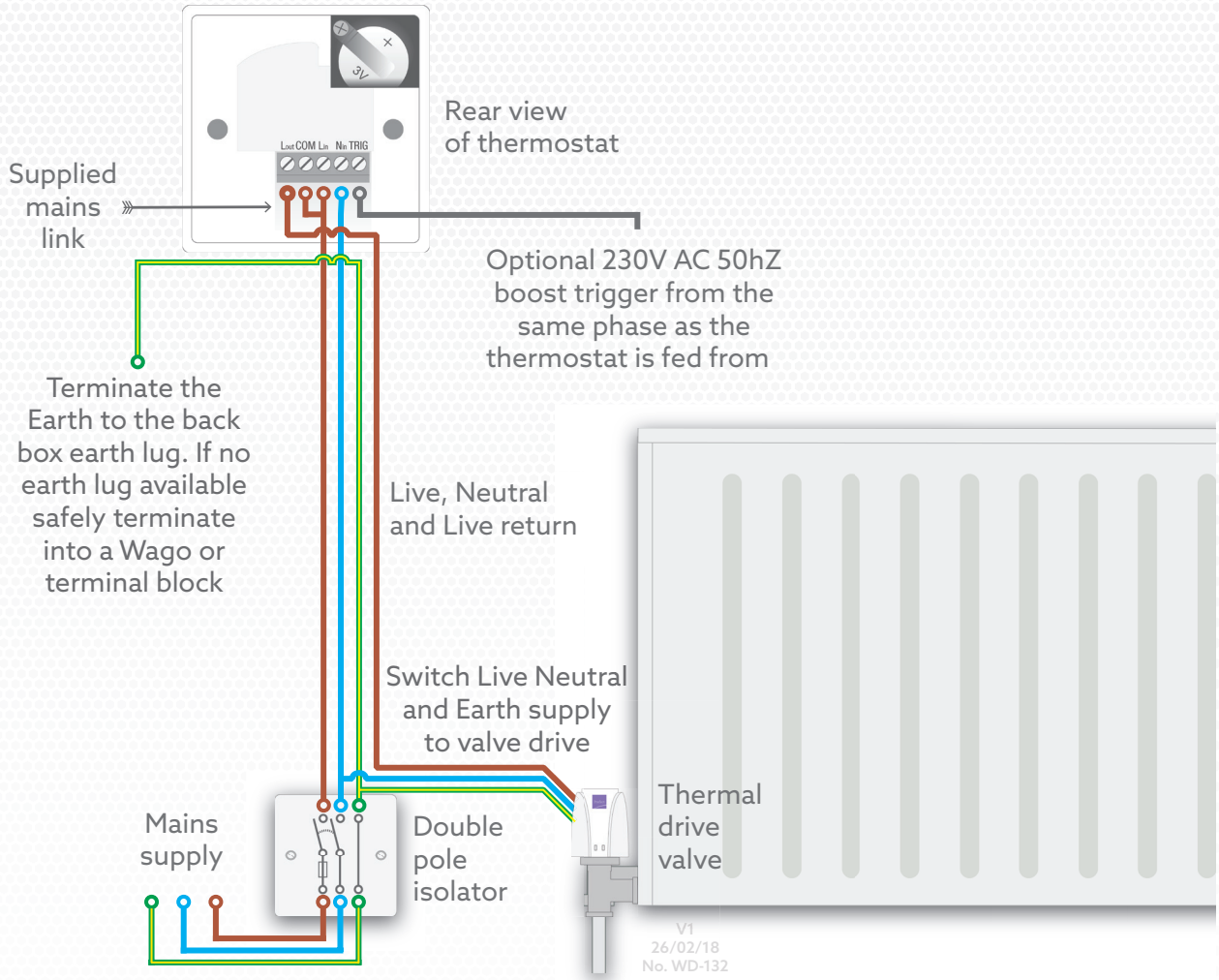

Not to scale

TERMINAL CONNECTIONS

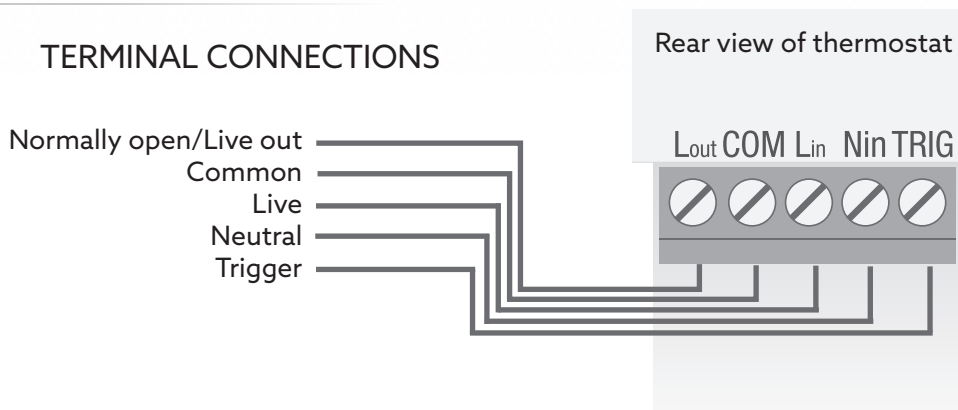

Due to our policy of continuous improvement, we reserve the right to change specifications without notice. All information was correct at time of when this product file was produced - April 2020

Touch Auto-on 3 stage infra-red settable intelligent thermostat with 7 day auto-on feature.

Cleverly simple control of energy.

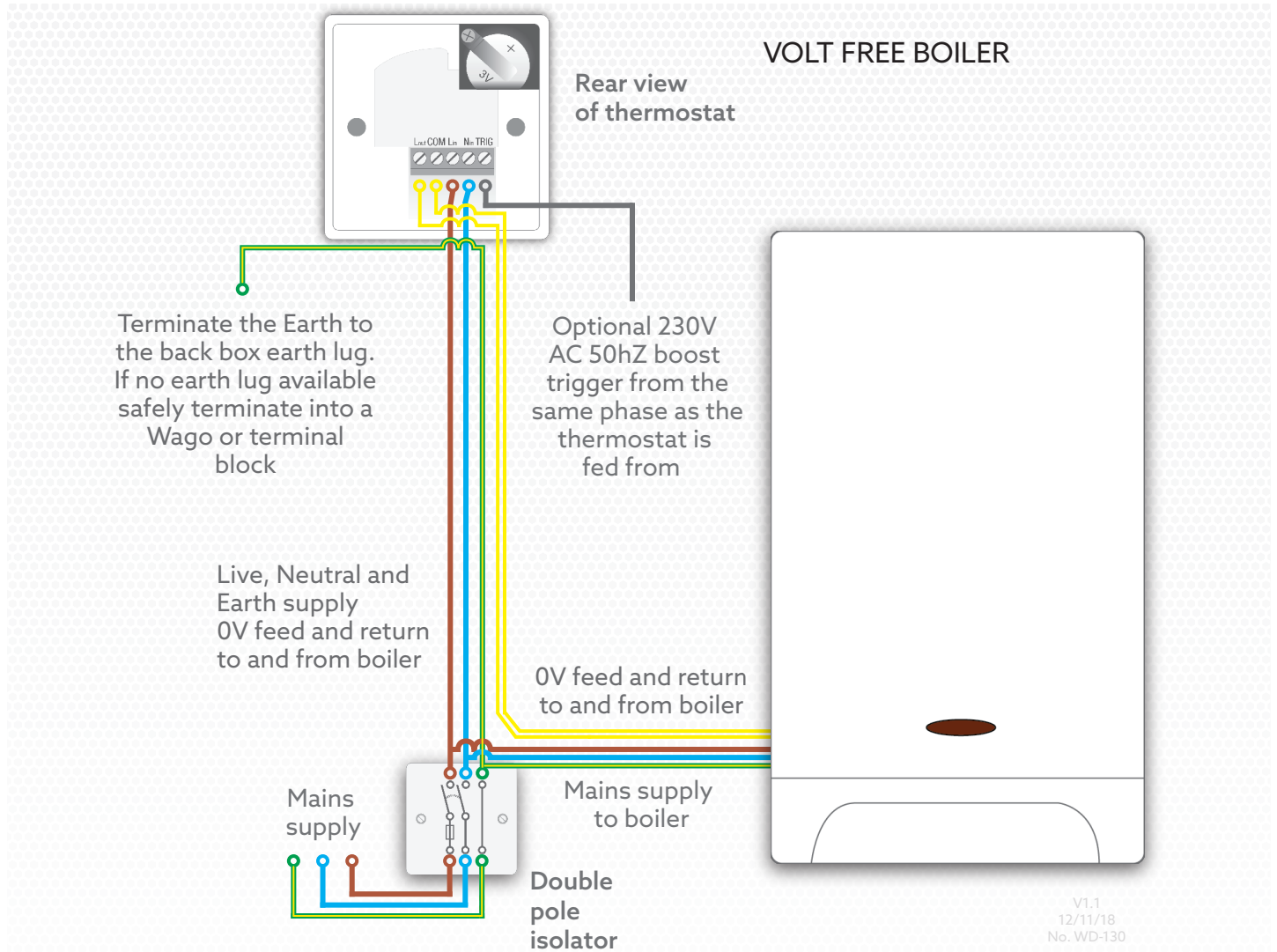

Not to scale

TERMINAL CONNECTIONS

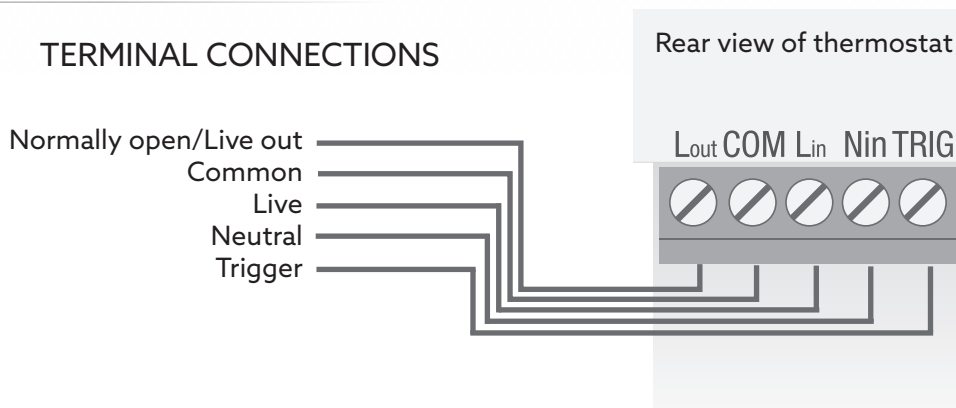

Due to our policy of continuous improvement, we reserve the right to change specifications without notice. All information was correct at time of when this product file was produced - April 2020

ecostat² PRE5004EC2



Instructions - page 9 of 22

Touch Auto-on 3 stage infra-red settable intelligent thermostat with 7 day auto-on feature.

Cleverly simple control of energy.

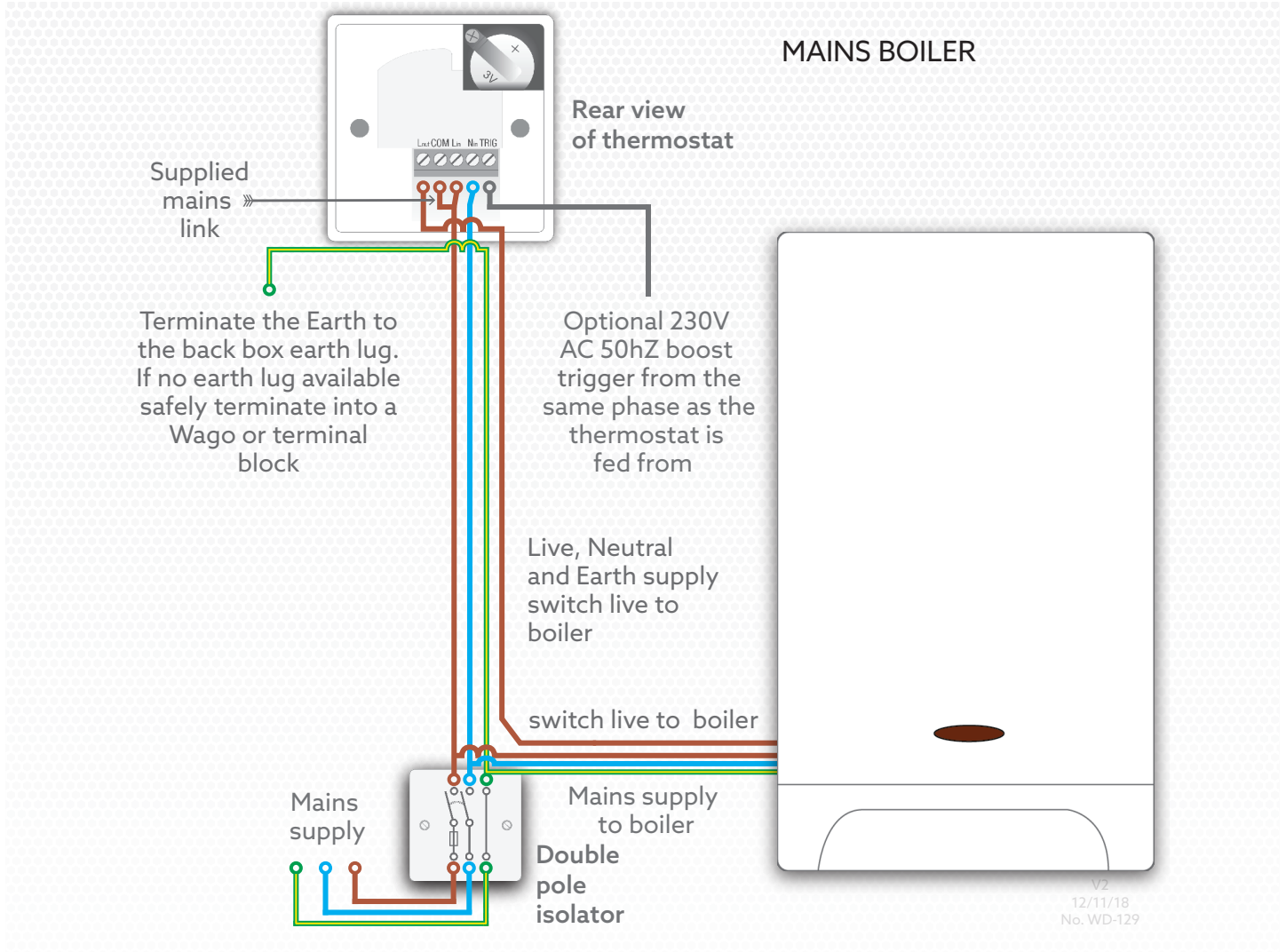

Not to scale

TERMINAL CONNECTIONS:

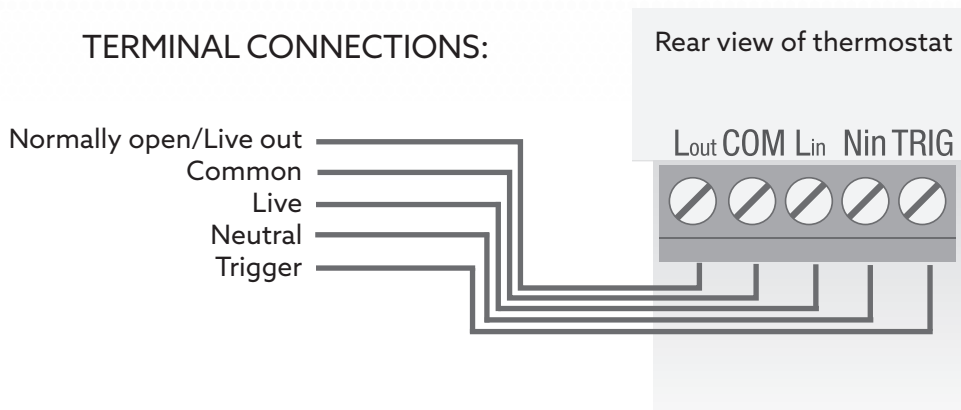



Due to our policy of continuous improvement, we reserve the right to change specifications without notice. All information was correct at time of when this product file was produced - April 2020



Cleverly simple
control of energy.

Touch Auto-on 3 stage infra-red settable intelligent thermostat with 7 day auto-on feature.

TROUBLESHOOTING

FAULT	CHECK
No LEDs are lit	<ol style="list-style-type: none">1. Check the unit is wired as per the wiring section starting on page 5 or the wiring diagram document.2. Check the mains supply voltage, ensure that 216-253V AC are present and stable between Lin and Nin terminals.
The load does not turn on	<ol style="list-style-type: none">1. Ensure there is power to the load if not fed by the thermostat, for example a volt free boiler connection.2. Check the unit is wired as per the wiring section starting on page 5 or the wiring diagram document.3. Check that the  LED is lit. This LED will only light when the thermostat relay is closed. If the LED is off the relay is open. If the LED is lit the thermostat is calling for heat.4. Check that the current room temperature is not above that of the thermostat set-point. If the room temperature is above the temperature set-point the thermostat will not close it's relay to heat until the room temperature falls below the set-point.5. If wired in a mains output configuration ensure the mains link has been fitted between the COM and Lin terminals.6. If the load is not turning on at a programmed auto-on event time, check that the auto-on events have been correctly programmed into the thermostat. Check the current time has been set. Programmed auto-on timings can be read using the PRE5901 handset. See PRE5901 instructions for details. NOTE: the auto on feature is omitted when the thermostat is in frost mode.
The load does not turn off	<ol style="list-style-type: none">1. Check the unit is wired as per the wiring section starting on page 5 or the wiring diagram document.2. Check that the  LED is not lit. This LED will only light when the thermostat relay is closed. If the LED is off the relay is open. If the LED is lit the thermostat is calling for heat and therefore the load will not switch off until heating is complete.3. Check that the current room temperature is not below that of the thermostat set-point. If the room temperature is below the current temperature set-point the thermostat will not open it's relay to discontinue heating until the room temperature is raised above that of the set-point.4. If wired in a volt free contact configuration ensure the mains link has been removed.5. Check that the clock auto-on function has not activated. Programmed auto-on timings can be read using the PRE5901 handset. See PRE5901 instructions for details.6. Check the trigger is not active, if 216-253VAC is supplied to the TRIG terminal the thermostat will stay in boost mode until the voltage is disconnected.

Due to our policy of continuous improvement, we reserve the right to change specifications without notice. All information was correct at time of when this product file was produced - April 2020



Touch Auto-on 3 stage infra-red settable intelligent thermostat with 7 day auto-on feature.

Cleverly simple
control of energy.

TROUBLESHOOTING

FAULT	CHECK
The LED's are flashing and the buttons do not work	This is normal after first power up. The thermostat stays dormant for 1 minute while the unit stabilises. Once this time has elapsed the unit will function as normal.
The load switches off after 2 minutes	The thermostat has a 2 minute test cycle/pre-warm, when the unit is boosted from setback or frost, or triggered via the clock or trigger the thermostat will heat regardless of temperature for 2 minutes. Once this time run has elapsed the thermostat will resume temperature sensing. If the load is switching off after this time the temperature set-point is below that of the room temperature meaning there is no need for the load to be on.
The thermostat is always in boost mode	<ol style="list-style-type: none">1. A mains voltage is present at the trigger (TRIG) terminal holding the unit in boost mode.2. Foreign substance jamming the up button.3. Auto-on is active. Programmed auto-on timings can be read using the PRE5901 handset. See PRE5901 instructions for details.
The thermostat does not stay at set level	<ol style="list-style-type: none">1. The current run time has elapsed and the thermostat has changed to another mode.2. A foreign substance is jamming one of the buttons.3. A mains voltage is present at the trigger terminal (TRIG) changing the program to boost mode, the thermostat will return to setback mode once the voltage is removed.4. A time event has been triggered.

Touch Auto-on 3 stage infra-red settable intelligent thermostat with 7 day auto-on feature.

PROGRAMMING CHARACTERISTICS

The time and temperature profiles of the unit are factory set to a default setting, however further adjustments can be made on site via the PRE5901 programming handset (Please note the PRE5900 and PRE5903 are not compatible with the ecostat2 range). Once the unit has been wired and fitted as instructed in this manual, power up the unit. The unit will be dormant for 1 minute after initial power up to allow the thermostat to stabilise.

LED INDICATORS

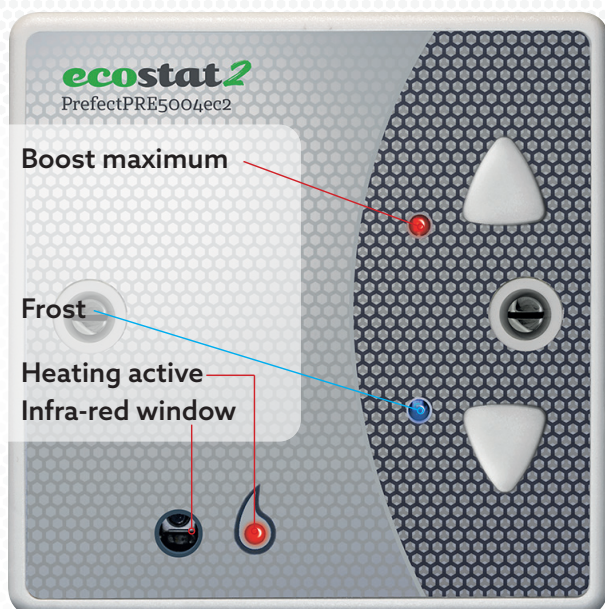

- **FROST** - This mode is used for long periods of absence. A temperature of 5°C is recommended to protect the fabric of the building. Frost is activated once the setback time has elapsed. Frost mode can also be selected by pressing the down button until only the blue LED is lit.

- **USER ADJUSTMENT** - The occupant can only select boost or frost mode.

- **TEST MODE/PRE-HEAT** - When the thermostat is boosted by either a time event, mains trigger or an up button press, the thermostat will enter boost mode. For the first 2 minutes of the boost cycle temperature sensing is omitted and the thermostat will heat regardless of temperature. After the 2 minutes has elapsed temperature sensing is re-enabled and the thermostat will continue the boost cycle. This cycle can take place only once during a boost cycle and once every hour unless the boost cycle is of more than an hour in which case the cycle can only take place once.

PROGRAMMING STATES

- **BOOST** - This mode is typically a relatively short run time, 45 to 120 minutes is recommended, with a comfortable room temperature, when the room is occupied, of usually 20-23°C. The boost mode is activated either by the up button being pressed or the thermostat receiving a boost trigger voltage from an external source or an auto-on time event.

- **SETBACK** - This mode typically uses a medium length run time, 12 to 48hrs is recommended. A temperature of 20-30% less than the boost temperature is recommended, this setting is used for short periods of absence. Setback mode is enabled when the boost run time has elapsed.

Due to our policy of continuous improvement, we reserve the right to change specifications without notice. All information was correct at time of when this product file was produced - April 2020



Cleverly simple
control of energy.

Touch Auto-on 3 stage infra-red settable intelligent thermostat with 7 day auto-on feature.

PROGRAM CHARACTERISTICS

• 230VAC REMOTE TRIGGER

The thermostat can be remotely triggered into boost mode by applying a mains voltage to the trigger terminal (TRIG) on the thermostat. When the mains voltage is applied for less than 30 seconds the thermostat will enter boost mode, the thermostat will complete the boost run time. When the voltage is applied for more than 30 seconds the thermostat will stay in boost mode until the trigger voltage is disconnected. Once the trigger has been disconnected the thermostat will immediately enter setback mode and resume the normal program cycle. While the trigger is active the end user can cancel the current boost cycle by pressing the down button. The 2 minute preheat/test cycle does apply to the live trigger.

• TIME EVENT AUTO-ON 7 DAY PROGRAMMING

Auto-on will trigger the thermostat into boost mode at 1 or 2 points during each day 7 days a week. The auto-on feature is programmed using the PRE5901 handset. Please note that a battery must be purchased and fitted into the thermostat (see page 21). Once the battery has been installed the real time clock must then be set. Clock setup is programmed via the PRE5901 handset (see PRE5901 instructions). Once programmed the thermostat will boost automatically at the set time and run the boost time. The 2 minute pre heat/test cycle applies to the auto-on cycle, the 2 minutes is inclusive of the boost time. When a time event is active the end user can cancel boost mode by selecting frost mode. If a time event is required for more than the boost time, you can combine two time events to make 1 extended time event. For example if your boost time is 60 minutes and you desire the heating to be active from 09:00 until 10:30 you can set the first time event for 09:00 then set the second time event at 09:30 this will achieve a 90 minute run time.

NOTE: the auto-on time events do not occur when the thermostat is in frost mode.

• OPTISTART

The thermostat has an optimum start feature. The optimum start feature ensures the room is at the required temperature at the set time event. The thermostat will learn how long it takes to raise the temperature of the room it is controlling. Using this information the thermostat will calculate how long before the time event the thermostat must start heating to achieve the boost temperature at the time event. This ensures the room is at the required temperature at the required time without having to set the time event early to ensure the room is to temperature which may waste energy.

CARE AND MAINTENANCE

When undertaking any care or maintenance work the thermostat **MUST** be correctly isolated. To clean the thermostat use a damp cloth with a mild detergent, do not allow any moisture to enter the thermostat. Do not use any solvent based cleaners as these may damage the thermostat. If the room is to be painted the thermostat must be isolated and either removed from the wall by a qualified person or correctly masked. If paint or debris are allowed into the thermostat or the vents become blocked this will stop the thermostat from working correctly. If the thermostat vents become blocked by dust or debris use an aerosol duster to blow out the dust. Under no circumstances is the thermostat to be dismantled, dismantling the thermostat will void the warranty.



Touch Auto-on 3 stage infra-red settable intelligent thermostat with 7 day auto-on feature.

Cleverly simple control of energy.

PROGRAM GRAPHS

The graphs below indicate the thermostats 3 mode temperature set points: boost, setback and frost modes. The graphs also show how the thermostat is triggered by the 3 boost triggers, these being a button press, mains trigger or an auto-on time event.

The graphs time is not to scale.

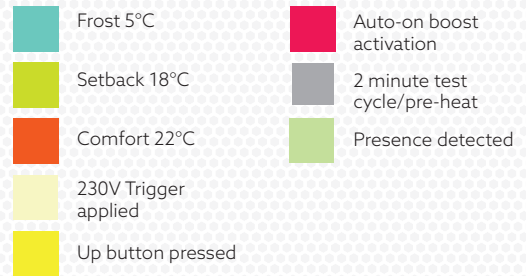

STANDARD BUTTON ACTIVATED

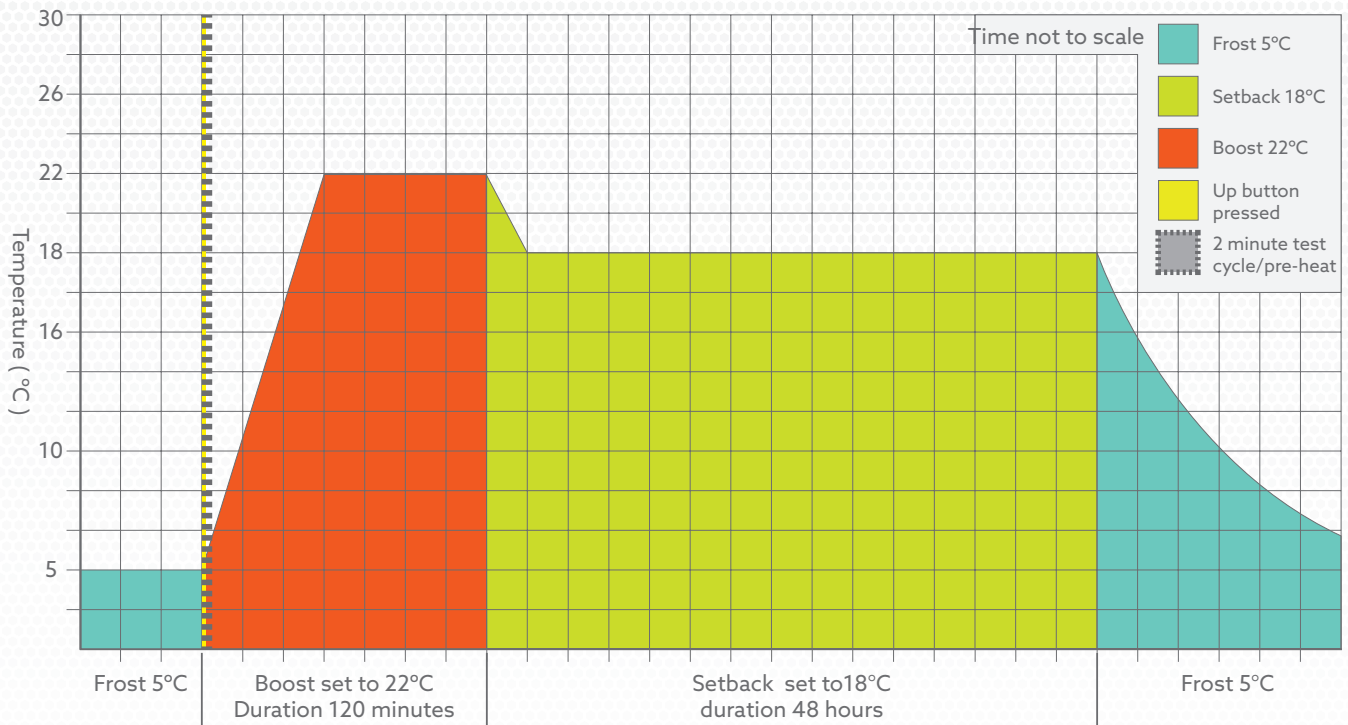

This graph shows how the thermostat reacts to presence, for this example the thermostat is set to the following settings:

- Frost 5°C
- Setback 18°C for 48 hours
- Boost 22°C for 120 minutes
- Auto-on - disabled

At the start of the graph the thermostat is in frost mode indicated in blue, the thermostat is maintaining 5°C.

The up button is pressed triggering the thermostat into boost mode the yellow line shows the button has been pressed and the red segment of the graph indicates

boost mode. The thermostat will call for heat until the boost temperature is reached in this case 22°C. For the first two minutes of the boost cycle the thermostat will call for heat regardless of temperature, this is indicated by the dashed grey line. The thermostat will remain in boost mode for the preset 120 minutes, Once this time has elapsed the thermostat will enter setback mode indicated in green. The thermostat will allow the room temperature to drop until the setback temperature is achieved in this case 18°C. The thermostat has not been touched for 48 hours so the thermostat enters frost mode and allows the temperature to drop to 5°C in this case, the thermostat maintains the frost temperature.

Due to our policy of continuous improvement, we reserve the right to change specifications without notice. All information was correct at time of when this product file was produced - April 2020

Touch Auto-on 3 stage infra-red settable intelligent thermostat with 7 day auto-on feature.

Cleverly simple control of energy.

PROGRAM GRAPHS

TRIGGER AND AUTO-ON ACTIVATED

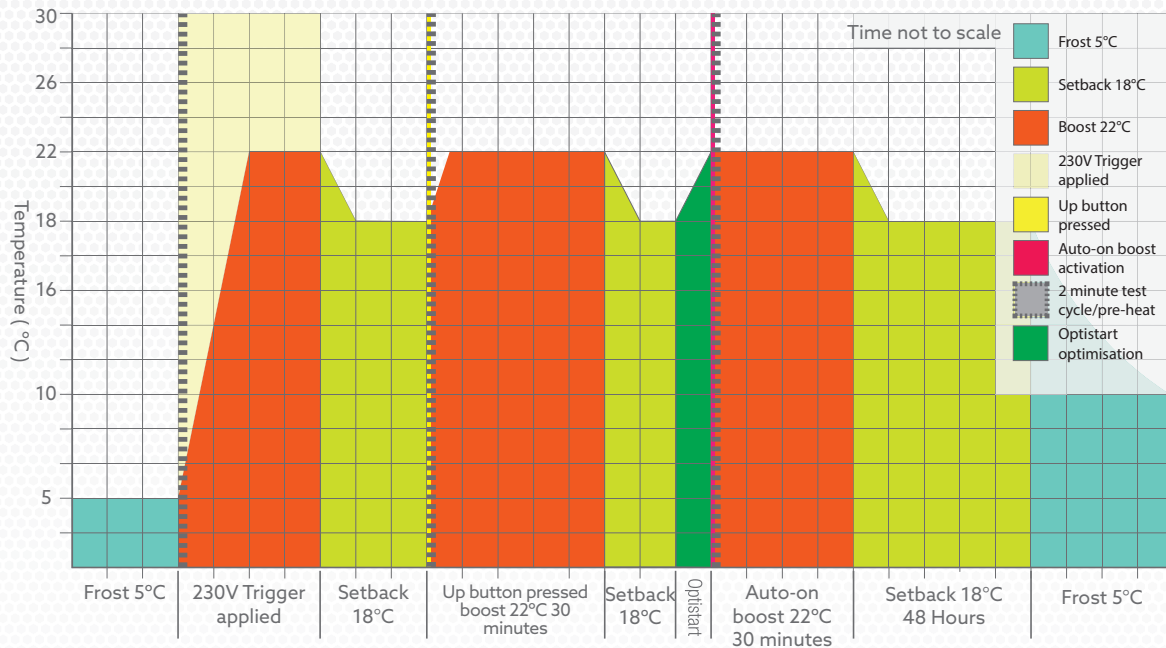

This graph shows how the thermostat reacts to a mains trigger and an auto-on event, for this example the thermostat is set to the following settings:

- Frost 5°C
- Setback 18°C for 48 hours
- Boost 22°C for 30 minutes
- Auto-on enabled and Optistart enabled

The Graph begins with the thermostat in frost mode indicated in blue. A boost trigger is applied to the thermostat indicated in yellow, the thermostat enters boost mode indicated in red and starts a 2 minute cycle where temperature sensing is omitted and the thermostat will call for heat continuously regardless of temperature. In this example the room temperature is still below the boost temperature set point after the 2 minute cycle so the thermostat continues calling for heat until the boost temperature is reached in this example 22°C. The thermostat will maintain the boost temperature set point until the boost trigger voltage is disconnected. The voltage is disconnected and the

thermostat enters setback mode indicated in green, the thermostat allows the room temperature to fall, once the room temperature drops to the setback temperature set point the thermostat will maintain the setback temperature in this case 18°C. The up button is pressed indicated by the yellow line, the thermostat completes the 2 minute cycle and in this case continue heating until the boost temperature set point is reached. The thermostat maintains the boost temperature for the preset 30 minutes. Once the 30 minutes have elapsed the thermostat returns to setback mode. An auto-on event time is programmed indicated by the purple line, this triggers the thermostat into boost. Optistart is enabled, Optistart will begin heating before the auto-on event to ensure the room is at temperature at the correct time, this is indicated by the dark green section of the graph. During the auto-on event the thermostat maintains the boost temperature for the preset boost time of 30 minutes in this example. After the 30 minute boost time has elapsed the thermostat returns to setback mode for 48 hours before entering frost mode.

Due to our policy of continuous improvement, we reserve the right to change specifications without notice. All information was correct at time of when this product file was produced - April 2020



Cleverly simple
control of energy.

Touch Auto-on 3 stage infra-red settable intelligent thermostat with 7 day auto-on feature.

SPECIAL FUNCTIONS

• VALVE SERVICE CYCLE

The valve service cycle is a feature that allows you to operate a heating control valve periodically to maintain movement and prevent a valve from seizing. The valve service cycle can be set from 1 to 30 days. The thermostat will operate the valve for 5 minutes closing and opening the valve, this will occur once in the set time period. The valve service cycle default is set to 0, when set to 0 the valve service cycle is deactivated, to enable the feature use the PRE5901 Handset and navigate to Heating>Select Product>PRE5000ec2>Device Config>Valve Service Cycle (days) change the value from 0 to a required time in days.

• LED FALLBACK

The LED indicators on the thermostat will illuminate to maximum brightness when the thermostat is boosted by a button press, mains trigger or auto-on time event. The LEDs will dim after the state change, the duration the LEDs stay at maximum brightness before dimming and how far the LEDs dim is settable using the PRE5901 handset. Using the PRE5901 handset navigate to Heating>Select Product>PRE5000ec2>LEDs Fallback. Brightness is the percentage of power the LEDs will dim to, a lower percentage meaning a dim LED and vice versa. This value is settable to 10, 20, 30, 40 or 50% brightness, 50% being the brightest. Time (secs) is the duration of time the LEDs will stay at maximum brightness after a state change, this is settable between 1 and 120 seconds.

• WINDOW OPEN DETECTION

The window open detection detects an unusual drop in temperature and limits the output to the heater/radiator/boiler. This feature monitors temperature over a set period of time, if in this time the room temperature drops below a set level the thermostat will enter window open detection mode. While in this mode the thermostat limits output to the heater/radiator/boiler, this is a settable value of time called duty cycle. The thermostat does not limit power to the heater/radiator/boiler it simply reduces the amount of time the load is on. There are 3 settings for this feature, Time (mins), Temp (C) and Duty Cycle (mins). The time setting is the length at which the thermostat looks for a temperature drop. The temp setting is how many degrees the room temperature must drop in the selected time frame to activate window open detection mode. Duty cycle is how long the heater/radiator/boiler can be active for when the window open detection mode is active. When the duty cycle is set to 5 minutes the heater/radiator/boiler will be on for 5 minutes and off for 5 minutes. Window open detection mode only functions during the boost cycle, it is not active in setback or frost mode. When window open detection mode is active the top and bottom scale LEDs will flash alternately. To exit window open detection mode press the up button once. Once the up button is pressed the mode is deactivated and the thermostat will continue to monitor temperature. If the temperature increases the boost cycle will continue if the temperature does not increase window open will be reactivated. If the temperature drops below the detection point within the time frame again the window open detection will be reactivated.

Touch Auto-on 3 stage infra-red settable intelligent thermostat with 7 day auto-on feature.

Cleverly simple control of energy.

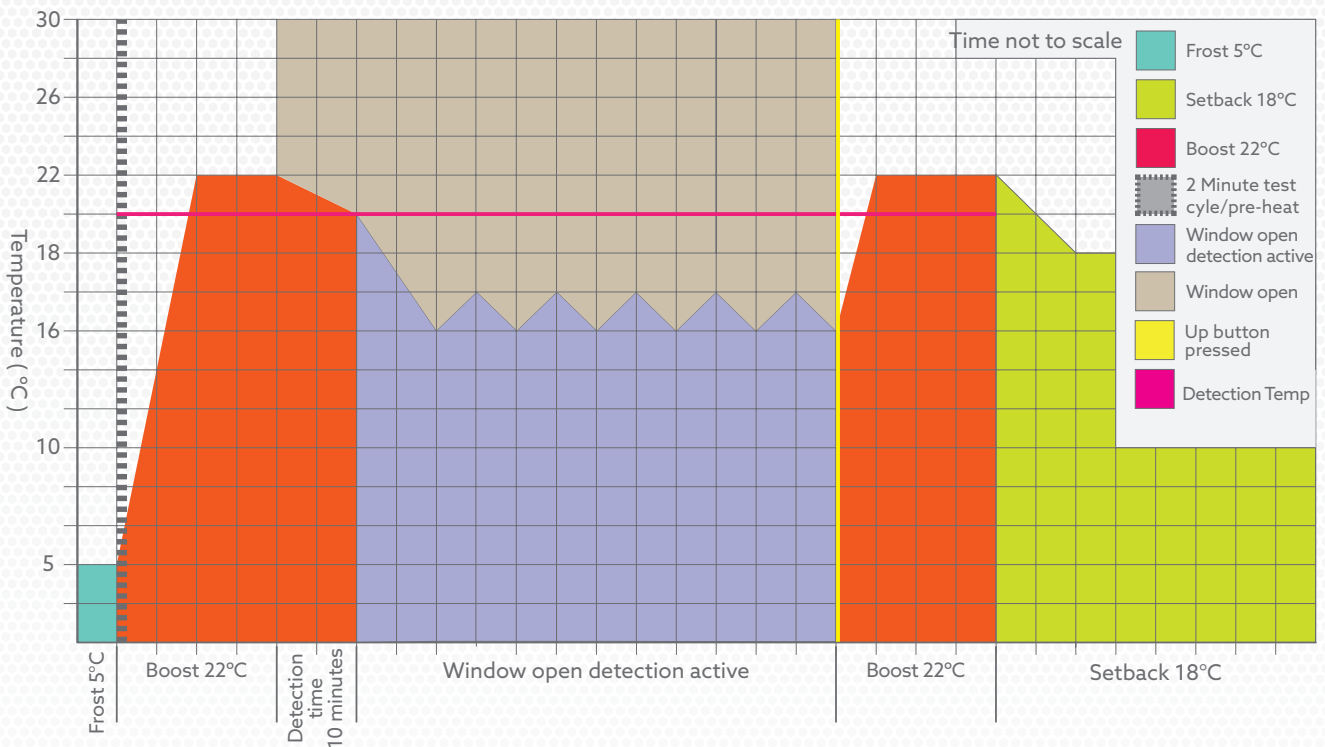

In the above example the thermostat is set to the following settings:

- Boost 22°C
- Setback 18°C
- Window open detection time 10 minutes
- Window open detection temp 2°C
- Window open detection duty cycle 5 minutes

The thermostat is boosted to 22°C, during the boost cycle the window is opened (indicated in brown). during a 10 minute period the temperature drops by 2°C. This activates the window open detection

mode, the thermostat limits output to 5 minutes off 5 minutes on. When the window is closed and the up button is pressed (indicated by the yellow line), the window open detection mode is deactivated and the temperature is restored to 22°C for the remainder of the boost cycle. Normal program operation resumes. If the up button is pressed and the temperature continues to drop, window open detection mode will be reactivated.

Settings can be found on the handset here:
 Heating>Select Product>PRE5000ec2>Window Open Detect. This feature is enabled by default, this feature can be disabled in the afore mentioned menu.

Due to our policy of continuous improvement, we reserve the right to change specifications without notice. All information was correct at time of when this product file was produced - April 2020

Touch Auto-on 3 stage infra-red settable intelligent thermostat with 7 day auto-on feature.

Cleverly simple control of energy.

PROGRAMMING

All thermostat parameters are set via the PRE5901 programming handset. Please note that the other Prefect IR handsets are not compatible with the ecostat2 series. For instructions on how to program the ecostat2 range and other Prefect infra-red products please see the PRE5901 instructions, available upon request or visit: www.prefectcontrols.com look under the products tab for Handsets and select PRE5901.

SENDING OR READING SETTINGS AND COMMANDS

To install settings into a product the settings must be "sent".

Settings can also be "read" from the product.

The settings are sent and read via an infra-red (IR) transmitter and receiver in the top of the handset.

The settings are received by a infra-red (IR) receiver on the product.

The infra-red is direct line of sight, meaning there must be a clear path between the handset and the product to be set.

The product to be set must be powered, the product can be set at anytime regardless of its current process. Installation of the settings is immediate.

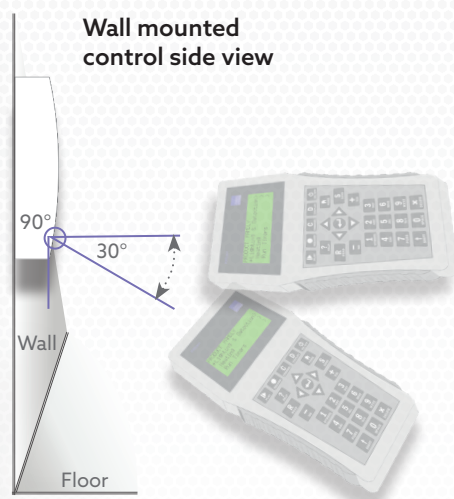

Point the top of handset at the IR window of the control (see page 12).

As above hold the handset between 90 and 30 degrees from the wall.

Hold the handset between 30cm to 3m from the control. The handset only needs to be pointed at the thermostat while the settings are being sent or read.

The handset needs to be kept pointing towards the thermostat until the read or send function is complete.

Short pressing the send or read key will read the current selected parameter. For example if the boost time is highlighted and the read button is pressed, only the boost time is read.

Long (press & hold) pressing either the send or read key, will send or read all parameters in one operation.

Keep the send or read key pressed until the handset sounds a bleep to confirm all parameters have either been read or sent.

The handset must be kept pointing towards the control during this operation until the beep is heard.

The thermostat will blink it's LEDs to confirm infra-red contact. If the LED does not light the infra-red signal is not being received, adjust the angle and or the distance of the handset until the control receives the commands.

Due to our policy of continuous improvement, we reserve the right to change specifications without notice. All information was correct at time of when this product file was produced - April 2020



Cleverly simple
control of energy.

Touch Auto-on 3 stage infra-red settable intelligent thermostat with 7 day auto-on feature.

PROGRAMMING PARAMETERS

PARAMETER	VALUE	FACTORY SETTING	DESCRIPTION
TEMPERATURE			
Frost (°C)	0-40°C	5°C	Frost temperature.
Setback (°C)	0-40°C	18°C	Setback temperature.
Boost (°C)	0-40°C	23°C	Boost Temperature.
Setback (hrs)	1-336 Hrs	6 Hrs	Timer run between boost mode ending and frost mode starting.
Boost (mins)	1-999 Mins	45 Mins	Boost run time. Does not apply when boosted by trigger for more than 30 secs.
Setback (mins)	1-59 Mins	0 Mins	For use when a setback time of less than 1 hour is required. Can also be used with setback hours for a higher time resolution, for instance 2 hours 45 minutes.
Current T (°C)	°C		Current room temperature as read by the thermostat.
CLOCK			
Day	Mon, Tue, Wed, Thu, Fri, Sat, Sun	-	Current day.
Time	00:00	0	Current time, in a 24 hour format.
Summer (+1 hr)		0	Advances the real time clock by 1 hour.
Winter (-1 hr)		0	Retards the real time clock by 1 hour.
Opti-Start enabled	Yes, No	No	Enables on or off for Opti-Start.
Max start Re-learn	1-60 Mins	60 Mins	Maximum start time for heating before scheduled timed event. Enables re-set so unit re-learns the thermal dynamics of the room to assess warm up time required.
EVENTS			
Day	Mon, Tue, Wed, Thu, Fri, Sat, Sun	-	Day in which the time event is to take place.
Event 1	Enabled, Disabled 00:00	0	Event 1 time and whether or not the time event is enabled.
Event 2	Enabled, Disabled 00:00	0	Event 2 time and whether or not the time event is enabled.

Due to our policy of continuous improvement, we reserve the right to change specifications without notice. All information was correct at time of when this product file was produced - April 2020



Cleverly simple
control of energy.

Touch Auto-on 3 stage infra-red settable intelligent thermostat with 7 day auto-on feature.

PROGRAMMING PARAMETERS

PARAMETER	VALUE	FACTORY SETTING	DESCRIPTION
ADVANCED FEATURES			
WINDOW OPEN DETECTION			
Enabled	Yes, No	Yes	Select if the window open detection is enabled.
Time (mins)	1-60 Minutes	20 Mins	The time duration of how long the detection period is.
Temp (C)	1-10°C	2°C	The required temperature drop within the detection time.
Duty Cycle (mins)	5-60 minutes	10 Mins	The duty cycle when the window open mode is active.
BOOST TRIGGER			
Time Event	Min, Med, Max	Max	Level of boost selected when a time event occurs.
Mains Trigger	Min, Med, Max	Max	Level of boost selected when a mains trigger is applied.
PIR Presence	Min, Med, Max	Max	Level of boost selected when presence detected.
LEDs FALLBACK			
Brightness %	10, 20, 30, 40, 50	20%	Brightness of LEDs once they have dimmed.
Time (secs)	1-120 seconds	5 Secs	How long the LEDs will remain at full brightness before dimming.
DEVICE CONFIGURATION			
Deep Sleep	Yes, No	?	Disables time keeping for periods with no mains power for battery conservation
Valve Service Cycle (days)	0-30 Days	-	Amount of days between a valve service cycle.
IR enabled	Yes or No	YES	Disables the infra-red setup from further adjustment without first re-enabling the infra-red. For instance when the infra-red is disabled the thermostat will not accept any settings until infra red is re-enabled. This can also be used for when 2 thermostats are in close proximity and require different settings.
Enable Mains Trigger	On, Off	On	Restarts the thermostat without altering any stored settings.
Soft Reset			Restarts the thermostat without altering any stored settings.
Factory Reset	AR-PRE5000		Returns all parameters of the thermostat to default settings, the handset settings are not changed.
TEMPERATURE			
Offset(C)	-1.5 to 1.5	0.0	Temperature calibration offset. Use this feature to offset the temperature calibration. For example if the thermostat is mounted on a cold wall and is measuring a degree less than the centre of the room, set the offset to -1°C.

Due to our policy of continuous improvement, we reserve the right to change specifications without notice. All information was correct at time of when this product file was produced - April 2020

Touch Auto-on 3 stage infra-red settable intelligent thermostat with 7 day auto-on feature.

Cleverly simple control of energy.

BATTERY CELL FITMENT & REPLACEMENT

The thermostats battery cell is required for operation of the auto-on feature. Once the battery cell has been depleted the auto-on feature will cease to function. However the thermostats other functions will not be affected and will continue to operate as normal. Please note that when the battery cell has been depleted only the current time is lost, all other settings are saved in the thermostats non-volatile memory.

Before undertaking any servicing work on the thermostat it is imperative that the mains supply to the thermostat and any trigger voltages have been safely isolated and locked off.

1. Perform safe isolation procedure.
2. Remove the thermostat from the fixing box.
3. Ensure there are no voltages present at any of the terminals.
4. Using a pair of electrical cutters, clip the 4 tabs on the top right battery cover and remove the cover(see fig 1).
5. Remove the battery retaining clip by removing the small machine screw, be sure to keep the screw in a safe place.
6. Remove the battery cell and dispose of it in an appropriate manner.
7. Insert the new battery cell, ensure the battery cell is inserted with the negative pole facing the negative pad on the PCB and the positive pole facing outwards.
8. Insert the retaining clip and replace the machine screw. Do not over tighten the fixing screw.
9. Ensure no conductors have been displaced during works.
10. Fit the thermostat back into it's fixing box.
11. Re-energise the supply circuit and any trigger circuits.
12. Check the thermostat is functioning correctly.
13. Using the PRE5901 programming handset, input the current time.

Fig 1

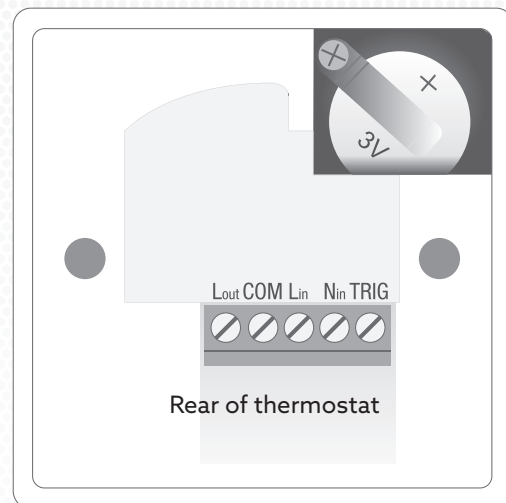
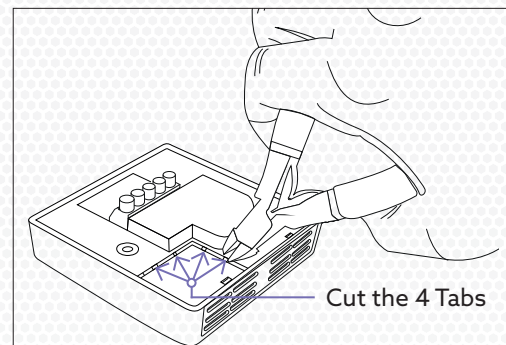

Battery cell fitted

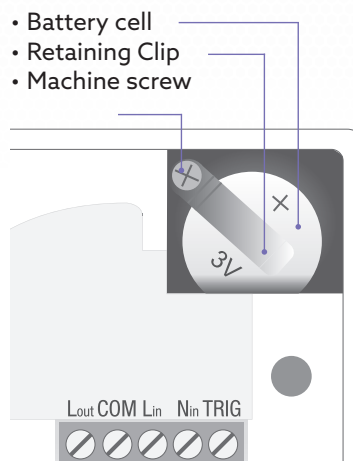

Battery cell removed

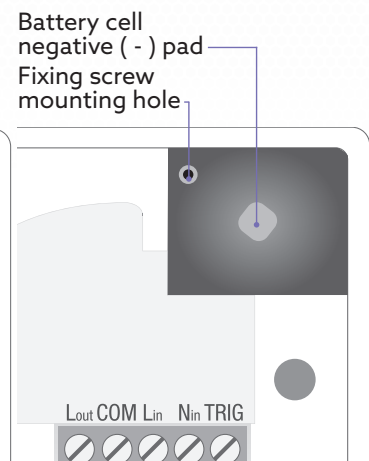

Due to our policy of continuous improvement, we reserve the right to change specifications without notice. All information was correct at time of when this product file was produced - April 2020



Cleverly simple
control of energy.

Touch Auto-on 3 stage infra-red settable intelligent thermostat with 7 day auto-on feature.

FREQUENTLY ASKED QUESTIONS

Can I mount the thermostat in a bathroom?

The thermostat is IP3X rated, therefore the thermostat can be mounted in zone 3.

Where do I mount the thermostat in a disabled room?

Mount the thermostat as close as possible to the central point of the room allowing for wheel chair access. Mount 1200mm from finished floor level.

Can I use two thermostats in the same room?

This is not recommended as the thermostats will contradict each other. The recommended solution is to control multiple heaters with a single thermostat. The thermostat can switch a combined heating load of up to 3.4kW. For a wiring diagram please visit prefectcontrols.com or contact a member of our staff. For loads above 3.4kW a contactor must be used.

Where do I mount the thermostat if it is controlling a boiler or heaters in multiple rooms?

When controlling multiple rooms mount the thermostat at the most central point between the rooms.

Can I mount the thermostat next to the heater/radiator?

The thermostat can be mounted next to the heater/radiator but must not be mounted within 300mm of the nearest edge of the heater and must not be mounted above the heater.

Can I mount the thermostat next to the heater/radiator?

The thermostat can be mounted next to the heater/radiator but must not be mounted within 300mm of the nearest edge of the heater and must not be mounted above the heater/radiator.

Can I use the thermostat to control a LV or 0V circuit?

Yes, the thermostat has a volt free contact, simply remove the supplied mains link that is fitted between the Lin and COM terminals. Terminate your LV or 0V supply to the COM terminal. Terminate the return to the Lout terminal.

Do I need any extra wiring accessories?

Yes, the thermostat must have a local means of safe double pole isolation. A PRE6000 double pole key switch is recommended. The thermostat must be mounted in a suitable 30mm or greater surface or sunken single gang box.

What is the live trigger for and do I have to use it?

When a mains voltage is applied to the trigger terminal the thermostat will enter boost mode. This allows the thermostat to be boosted by an external device such as a door switch, card reader or timer. This function is optional and does not need to be connected.

Do I have to connect an earth to the unit?

The thermostat does not have an earth connection as the unit is double insulated. Current regulations state that there should be an earth present at the back box. If available terminate the earth to the terminal in the back box. If no such terminal is present safely terminate the earth into a terminal block or Wago and leave in the back box.

What cable should I use to connect the thermostat?

Cable type and size is dependant upon installation configuration, ensure the cabling has appropriate load carrying capacity and conforms with regulations in force at time of installation. We recommend using a 3 and earth cable.

How do I change the settings?

Settings are changed via the infra-red programming handset the PRE5901. See page 18 & 19.

How much control does the end user have?

The end user can only select temperature set points frost, setback or boost level. The end user can only select temperatures between the levels set by the handset. The end user cannot select how long the thermostat heats for.

Can the end user change the settings?

No the thermostat is tamper proof, the settings can only be changed by the handset.

Do I have to use the clock function?

No each time event can be activated or deactivated via the handset. See pages 18-20.

Do I have to use Optistart?

No, the Optistart feature can be deactivated using the handset. pages 18-20.

Do I have to use the window open detection?

No, the window open detection can be deactivated using the handset. pages 18-20.