

Touch PIR auto-on 3 stage infra-red settable intelligent PIR thermostat with 7 day auto-on feature.

Cleverly simple control of energy.



SPECIFICATION

Size

Standard single gang plate size. Requires a 30mm deep surface pattress or 25mm or greater sunken box. When mounting into a sunken wall box or metal clad box remove the top and bottom mounting lugs of the box.

Supply voltage

216-253V AC at 50Hz.

Load

16A Resistive, not suitable for use with quartz heaters.

Electrical connections

Live in (Lin), Neutral (Nin), Common (COM), Normally open/live out (Lout), 216-253V AC 50Hz Boost Trigger (TRIG).

Terminal capacity

6mm² Maximum cable CSA, internal terminal size 2.9mm x 4mm.

Indicators

Heating active, Frost, Boost.

Adjustment

Frost or Boost selection, button selected.

Programs

Boost, Setback, Frost.

Pir modes

Absence or presence selectable (handset required not supplied).

Pir detection range

5m at 58°

Timing range

Boost 0-999 minutes, Setback 0 minutes to 999 hours, PIR time-out 0-999 minutes.

Temperature range

Boost, Setback and Frost 1 to 40°C.

Clock events

Two auto-on events per day, 7 day programmable.

Clock range

23 hours, 59 minutes

Clock cell

CR2477 3V, Available from Prefect using code PRE5001B (not supplied)

Clock cell life expectancy

Based upon 2 months per year the unit is powered down, 5 Years.

Programming method

AUTO LOCK SYSTEM © Secure infra-red programming via the PRE5901 handset.

Conformance

EMC-2004/108/EC LVD-2006/95/EC

ERP Class

ErP Class 1, SHE 1%

ERP seasonal heating efficiency 1%

Casing material

PC/ABS

Temperature Range

0°C to 40°C

Temperature accuracy

+/- 0.5°C

IP Rating

IP3X

Ecodesign Lot 20 compliant

Yes

Warranty

5 Years

Touch PIR auto-on 3 stage infra-red settable intelligent PIR thermostat with 7 day auto-on feature.

INDEX

INSTALLATION

What is the thermostats specification?	Page 1
Where and how do I mount the thermostat?	Page 3-4
What is the PIR detection range?	Page 5
How do I install the thermostat with an electric panel heater?	Page 6
How do I activate an Atlantic Energy Lock heater?	Page 7
How do I install the thermostat with a wet radiator?	Page 8
How do I install the thermostat with a volt free contact boiler?	Page 9
How do I install the thermostat with a mains boiler?	Page 10
How do I Troubleshoot the thermostat?	Page 11/12

PROGRAMMING

What do the LEDs mean?	Page 13
What does boost, setback and frost mean?	Page 13
How does the occupant adjust the thermostat?	Page 13
What do the PIR modes mean?	Page 13, 14
How does the live boost trigger work?	Page 15
How does the clock function work?	Page 15
How does optistart work?	Page 15
How does the PIR work?	Page 15, 16, 17, 18
How does the window open detection work?	Page 18

SETTINGS AND SETUP

What do the settings mean?	Page 20, 21, 22
How do I set the thermostat?	- See PRE5901 Instruction manual: IN-127 PRE5901

SERVICE

How do I install the battery?	Page 23
Frequently asked questions	Page 24

Touch PIR auto-on 3 stage infra-red settable intelligent PIR thermostat with 7 day auto-on feature.

INSTALLATION

- All installation and wiring works must be completed by a competent person and conform to relevant regulations in force at time of installation
- Locate the thermostat at least 300mm away from the nearest edge of the heater. Ensure the thermostat is placed where it cannot be affected by extraneous heat sources, for example: televisions, desktop computers, fridges. If fitted too close to an extraneous heat source the thermostat will not function correctly. Do not mount the thermostat above a heater or radiator. Mount the thermostat at the centre point of the room if possible. Do not mount the thermostat behind curtains or room dividers, for the PIR detector to work correctly the thermostat must have a clear view of the room.
- Ensure the thermostat has a local means of safe isolation. A double pole isolator must be used. A PRE6000 double pole key switch is recommended.
- Mount the thermostat between 1.2m and 1.4m from finished floor level. The thermostat is equipped with a PIR for presence detection, be sure to mount the thermostat in such a position to provide a clear view of the required detection area, the maximum detection range is 5m.
- The thermostat can be mounted in both surface and sunken boxes. When mounting into a metal clad pattress or sunken box the upper and lower box lugs must be removed.
- Ensure the thermostat is not mounted within 1m of forced heating or ventilation systems.
- Ensure the thermostat is not in a position to be covered or isolated from the room environment. Do not mount directly next to a window.
- Ensure the thermostat is easily accessible and does not put occupants or service engineers at risk of injury.

TYPICAL ELECTRICAL LAYOUT - Not to scale

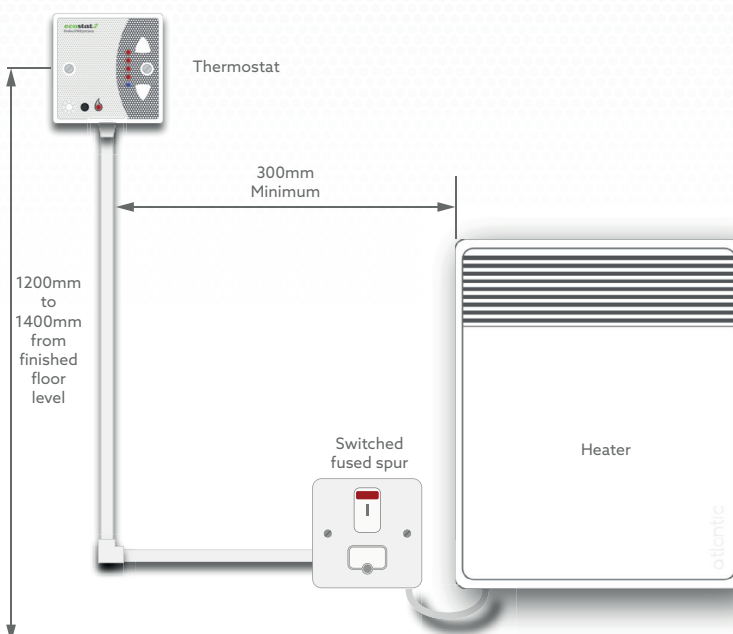

Due to our policy of continuous improvement, we reserve the right to change specifications without notice. All information was correct at time of when this product file was produced - April 2020

Touch PIR auto-on 3 stage infra-red settable intelligent PIR thermostat with 7 day auto-on feature.

INSTALLATION

- All installation and wiring works must be completed by a competent person and conform to relevant regulations in force at time of installation
- Locate the thermostat at least 300mm away from the nearest edge of the radiator. Ensure the thermostat is placed where it cannot be affected by extraneous heat sources, for example: televisions, desktop computers, fridges. If fitted too close to an extraneous heat source the thermostat will not function correctly. Do not mount the thermostat above a heater or radiator. Mount the thermostat at the centre point of the room if possible. Do not mount the thermostat behind curtains or room dividers, for the PIR detector to work correctly the thermostat must have a clear view of the room.
- Ensure the thermostat has a local means of safe isolation. A double pole isolator must be used. A PRE6000 double pole key switch is recommended.
- Mount the thermostat between 1.2m and 1.4m from finished floor level. The thermostat is equipped with a PIR for presence detection, be sure to mount the thermostat in such a position to provide a clear view of the required detection area, the maximum detection range is 5m.
- The thermostat can be mounted in both surface and sunken boxes. When mounting into a metal clad pattress or sunken box the upper and lower box lugs must be removed.
- Ensure the thermostat is not mounted within 1m of forced heating or ventilation systems.
- Ensure the thermostat is not in a position to be covered or isolated from the room environment. Do not mount directly next to a window.
- Ensure the thermostat is easily accessible and does not put occupants or service engineers at risk of injury.

TYPICAL WET LAYOUT - Not to scale

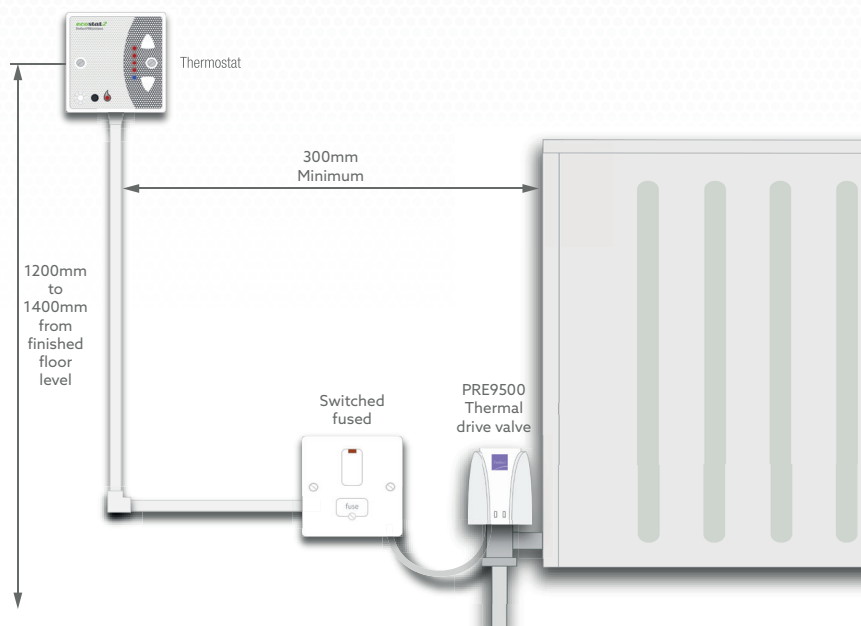

Due to our policy of continuous improvement, we reserve the right to change specifications without notice. All information was correct at time of when this product file was produced - April 2020

Touch PIR auto-on 3 stage infra-red settable intelligent PIR thermostat with 7 day auto-on feature.

Cleverly simple control of energy.

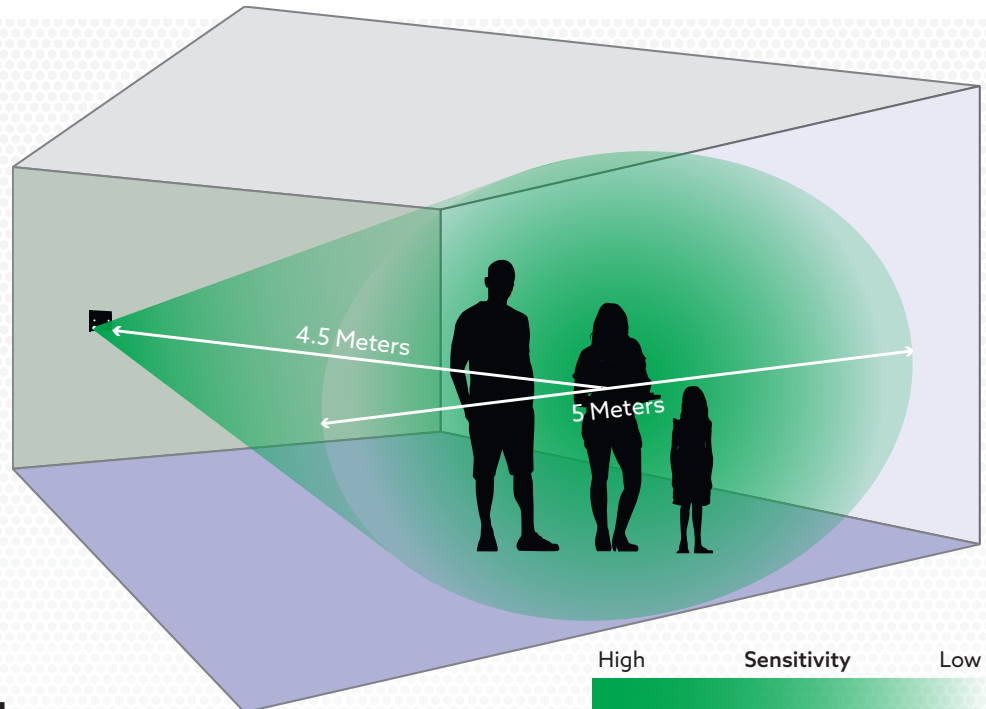

PIR DETECTION

DETECTION PARAMETERS - Not to scale

The thermostat utilises a PIR passive infra-red detector to detect occupants in the room the thermostat is controlling. When installing the thermostat considerations must be made to the position of the thermostat so the unit has optimal temperature sensing whilst being positioned to allow the thermostat a clear view of the required detection area. The PIR cannot see around corners or through objects for instance walls, curtains or room dividers. The PIR requires a clear unobstructed view of the detection area. The thermostat should have a clear view of the room that it is controlling. The PIR has a total detection range of 4.5m from the thermostat at a 58° Angle. At 4.5m distance from the thermostat the detection area is of a 5m diameter this will differ slightly due to position and room layout. The PIR is most sensitive at close range and least sensitive at the end of its range take this into account when positioning the thermostat. Please note that these detection parameters are based on the thermostat being mounted at the correct height of 1.2 to 1.4m from finished floor level.

CARE AND MAINTENANCE

When undertaking any care or maintenance work the thermostat MUST be correctly isolated. To clean the thermostat use a damp cloth with a mild detergent, do not allow any moisture to enter the thermostat. Do not use any solvent based cleaners as these may damage the thermostat. If the room is to be painted the thermostat must be isolated and either removed from the wall by a qualified person or correctly masked. If paint or debris is allowed into the thermostat, or the vents become blocked, this will stop the thermostat from working correctly. If the thermostat vents become blocked by dust or debris use an aerosol duster to blow out the dust. Under no circumstances is the thermostat to be dismantled, dismantling the thermostat will void the warranty.

Due to our policy of continuous improvement, we reserve the right to change specifications without notice. All information was correct at time of when this product file was produced - April 2020

Touch PIR auto-on 3 stage infra-red settable intelligent PIR thermostat with 7 day auto-on feature.

Cleverly simple control of energy.

WIRING

MAINS OUTPUT

1. All wiring works should be completed by a competent person/s. Isolate the appropriate circuit that the thermostat is to be supplied from. Perform safe isolation procedure to ensure the circuit is completely isolated. Ensure the supply has been locked in the off position. Always ensure safe working practices.
2. Make any circuit adjustments required in accordance with current regulations.
3. If the trigger terminal is to be used ensure the trigger supply is fed from the same circuit as the thermostat supply to conform with current regulations.
4. Connect the live and neutral supply to the thermostat, note that the load neutral must be fitted with the supply neutral. Ensure the supplied mains link is fitted between Lin and COM terminals, terminate the loads live supply to the normally open terminal (Lout). Ensure the link is securely fastened in both the Lin and COM terminals.
5. Recheck all terminals including any factory fitted connections then fit the unit to the back box ensuring cables are not in a position to be damaged.
6. Re-energise the circuit. Press the up button twice to enable a 2 minute test cycle.

VOLT FREE OUTPUT

1. All wiring works should be completed by a competent person/s. Isolate the appropriate circuit that the thermostat is to be supplied from. Perform safe isolation procedure to ensure the circuit is completely isolated. Ensure the supply has been locked in the off position. Always ensure safe working practices.
2. Make any circuit adjustments required in accordance with current regulations.
3. If the trigger terminal is to be used ensure the trigger supply is fed from the same circuit as the thermostat supply to conform with current regulations.
4. Terminate the live and neutral supply to the thermostat. Ensure the supplied mains link is REMOVED.
5. Terminate the loads feed cable to the common (COM) terminal. Terminate the load return to normally open terminal (Lout).
6. Recheck all terminal connections and fit the unit to the back box ensuring cables are not in a position to be damaged.
7. Re-energise the circuit. Press the up button twice to enable a 2 minute test cycle.

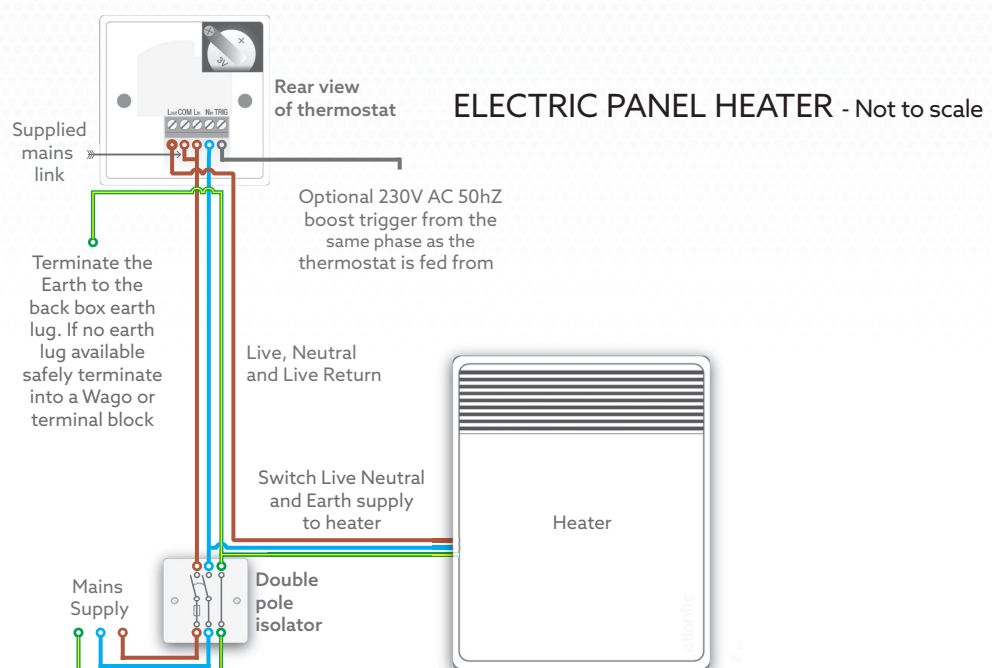

Due to our policy of continuous improvement, we reserve the right to change specifications without notice. All information was correct at time of when this product file was produced - April 2020

Touch PIR auto-on 3 stage infra-red settable intelligent PIR thermostat with 7 day auto-on feature.



Cleverly simple
control of energy.

ATLANTIC HEATERS WITH ENERGY LOCK



When using an Atlantic panel heater with Prefect Energy Lock, a key (Fig 6) needs to be installed before the heater can be used.

- Holding the key with the tooth at the top, note the T shape of the tooth. On the top right hand side of the heater is a plastic cover, on this cover you will see a corresponding T slot. Locate the key into the T slot on the heater (see fig 7).
- Once the key is located into the T slot, push the key home until it is flush (see fig 8). Once the key is fitted the heater will be able to operate when the thermostat is calling for heat.

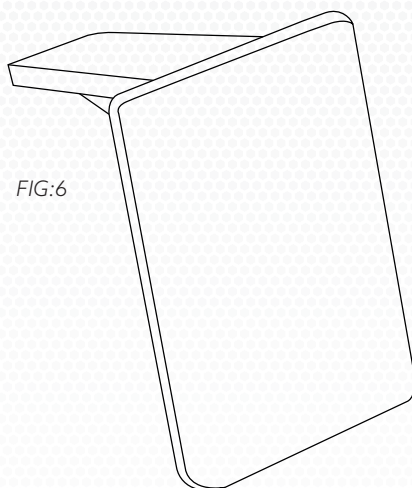

FIG:6

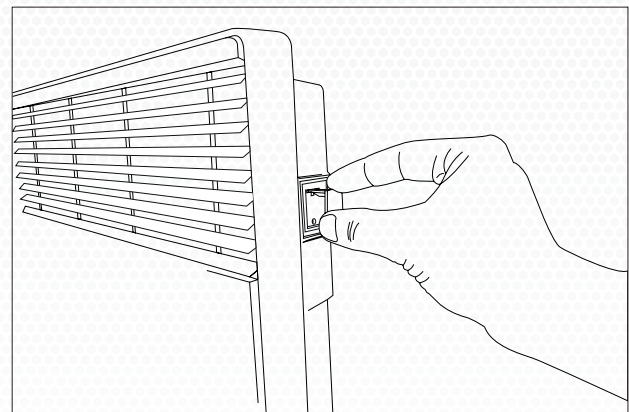

FIG:7

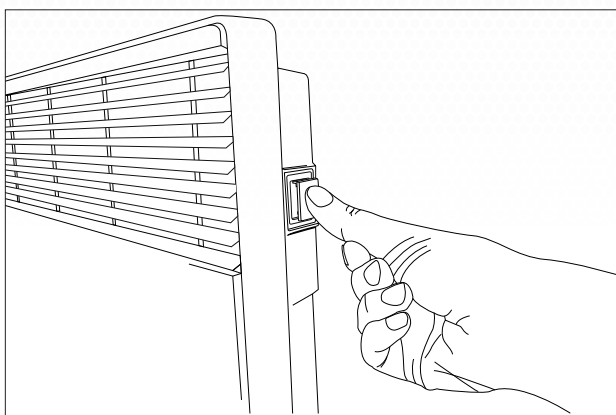

FIG:8

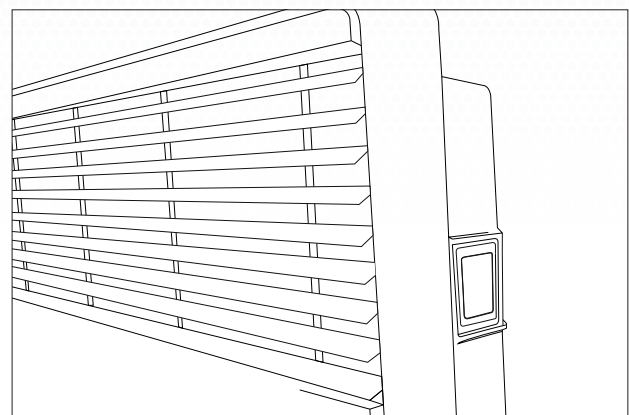

FIG:9

Due to our policy of continuous improvement, we reserve the right to change specifications without notice. All information was correct at time of when this product file was produced - April 2020

Touch PIR auto-on 3 stage infra-red settable intelligent PIR thermostat with 7 day auto-on feature.

Cleverly simple control of energy.

WET RADIATOR & VALVE DRIVE

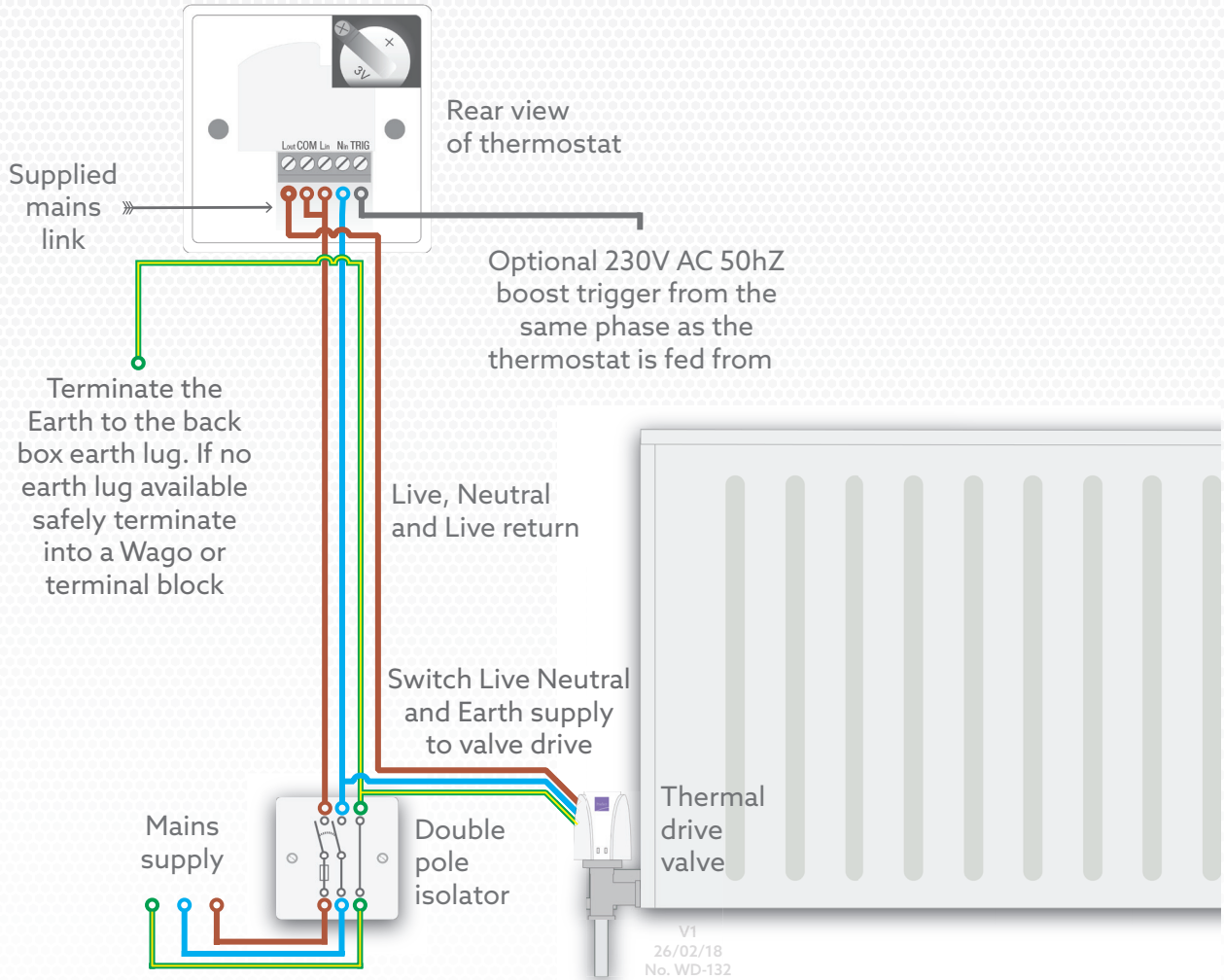

TERMINAL CONNECTIONS

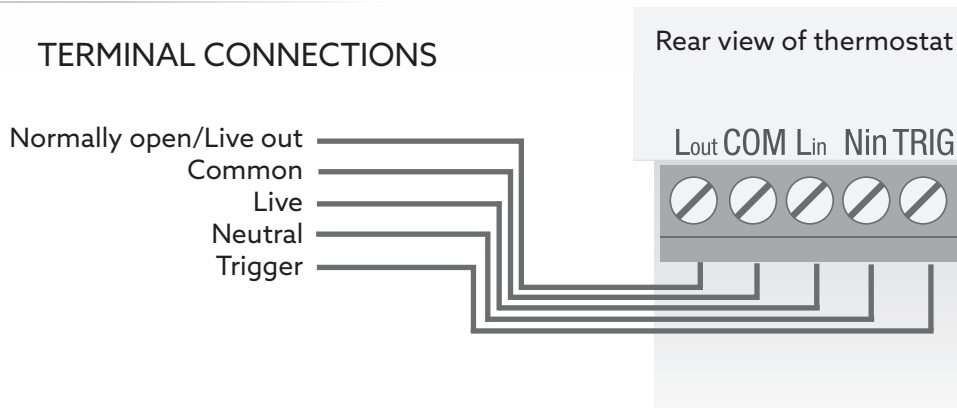

Due to our policy of continuous improvement, we reserve the right to change specifications without notice. All information was correct at time of when this product file was produced - April 2020

ecostat² PRE5204EC2

Instructions - page 9 of 24

Touch PIR auto-on 3 stage infra-red settable intelligent PIR thermostat with 7 day auto-on feature.



Cleverly simple control of energy.

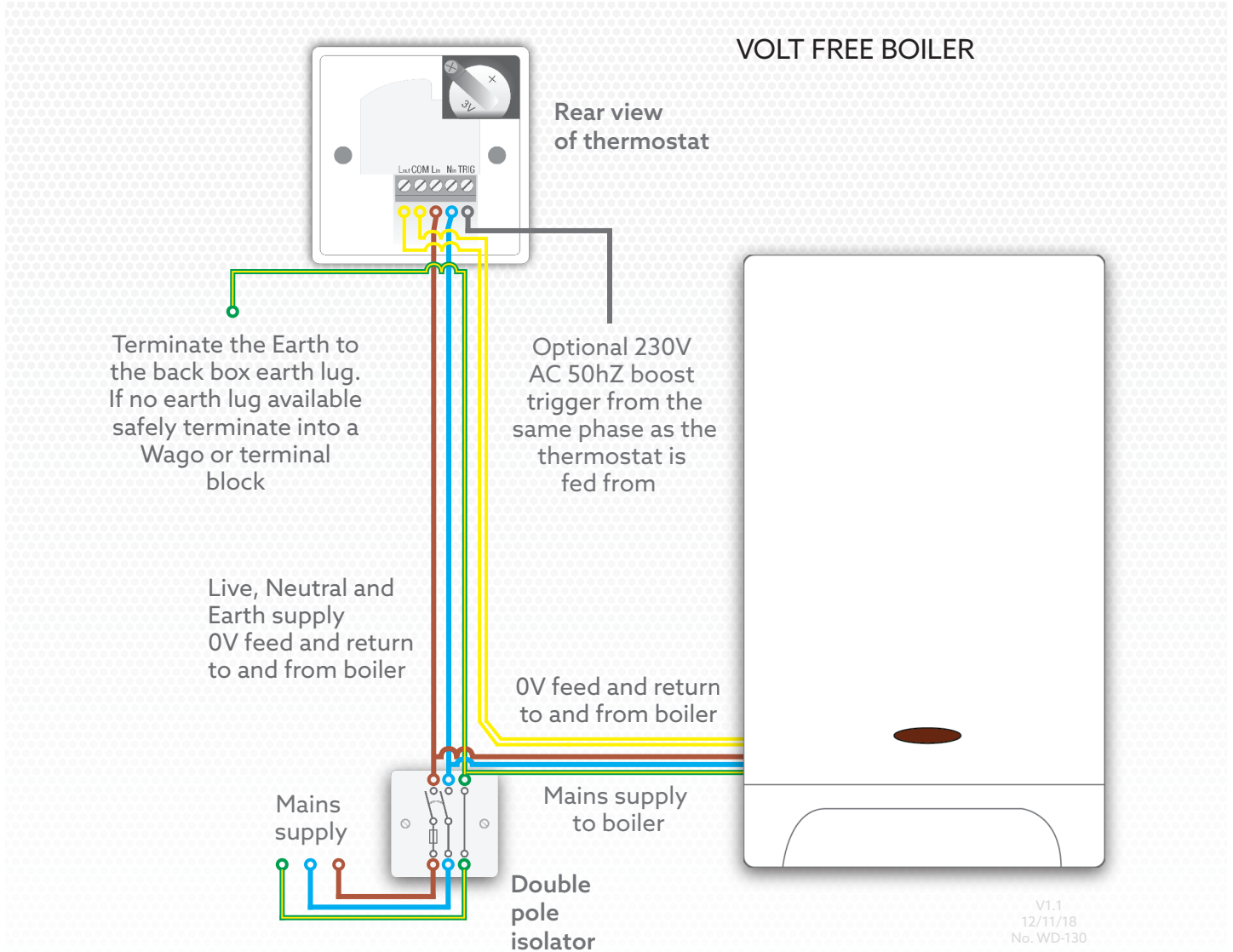

Not to scale

TERMINAL CONNECTIONS

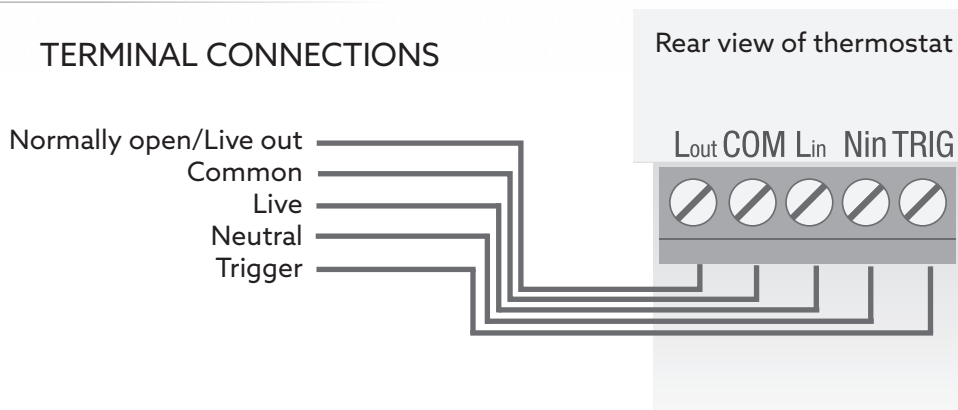

Due to our policy of continuous improvement, we reserve the right to change specifications without notice. All information was correct at time of when this product file was produced - April 2020

Touch PIR auto-on 3 stage infra-red settable intelligent PIR thermostat with 7 day auto-on feature.

Cleverly simple control of energy.

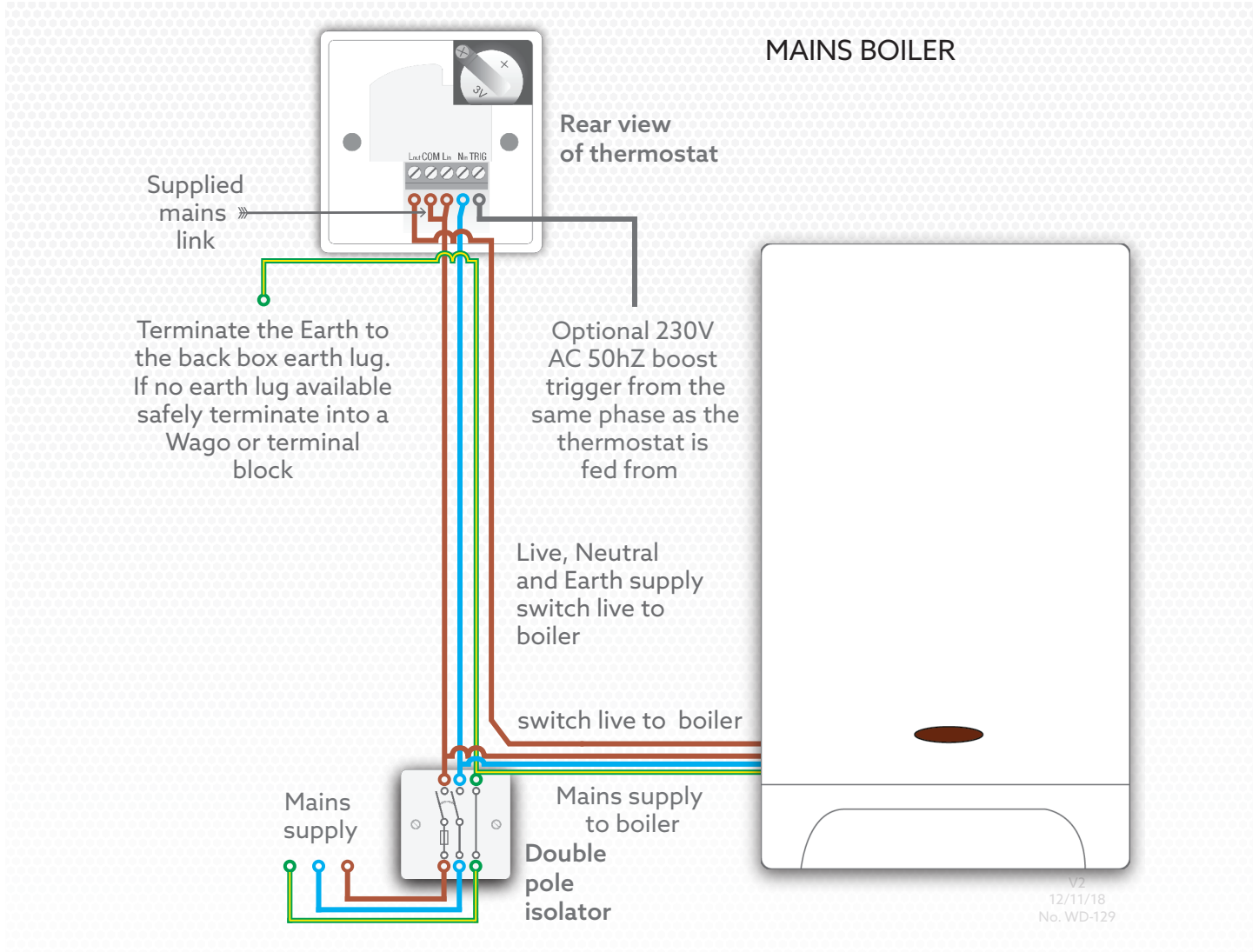

Not to scale

TERMINAL CONNECTIONS:

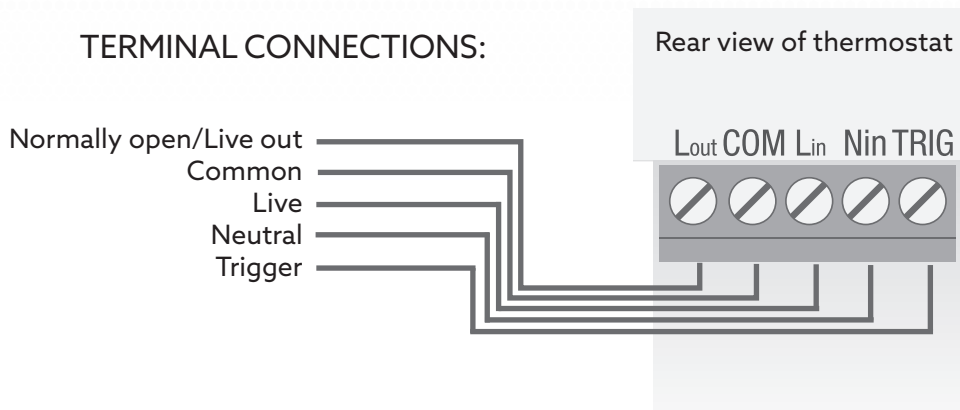



Due to our policy of continuous improvement, we reserve the right to change specifications without notice. All information was correct at time of when this product file was produced - April 2020



Cleverly simple
control of energy.

Touch PIR auto-on 3 stage infra-red settable intelligent PIR thermostat with 7 day auto-on feature.

TROUBLESHOOTING

FAULT	CHECK
No LEDs are lit	<ol style="list-style-type: none">1. Check the unit is wired as per the wiring section starting on page 6 or the wiring diagram document.2. Check the mains supply voltage, ensure that 216-253V AC are present and stable between Lin and Nin terminals.
The load does not turn on	<ol style="list-style-type: none">1. Ensure there is power to the load if not fed by the thermostat, for example a volt free boiler connection.2. Check the unit is wired as per the wiring section starting on page 6 or the wiring diagram document.3. Check that the  LED is lit. This LED will only light when the thermostat relay is closed. If the LED is off the relay is open. If the LED is lit the thermostat is calling for heat.4. Check that the current room temperature is not above that of the thermostat set-point. If the room temperature is above the temperature set-point the thermostat will not close it's relay to heat until the room temperature falls below the set-point.5. If wired in a mains output configuration ensure the mains link has been fitted between the COM and Lin terminals.6. If the load is not turning on at a programmed auto-on event time, check that the auto-on events have been correctly programmed into the thermostat. Check the current time has been set. Programmed auto-on timings can be read using the PRE5901 handset. See PRE5901 instructions for details. NOTE: the auto on feature is omitted when the thermostat is in frost mode.
The load does not turn off	<ol style="list-style-type: none">1. Check the unit is wired as per the wiring section starting on page 6 or the wiring diagram document.2. Check that the  LED is not lit. This LED will only light when the thermostat relay is closed. If the LED is off the relay is open. If the LED is lit the thermostat is calling for heat and therefore the load will not switch off until heating is complete.3. Check that the current room temperature is not below that of the thermostat set-point. If the room temperature is below the current temperature set-point the thermostat will not open it's relay to discontinue heating until the room temperature is raised above that of the set-point.4. If wired in a volt free contact configuration ensure the mains link has been removed.5. Presence is detected. If presence is detected the thermostat will stay in boost mode holding a higher temperature set-point, if you leave the room the time run will expire and the thermostat will turn down to setback mode.6. Check that the clock auto-on function has not activated. Programmed auto-on timings can be read using the PRE5901 handset. See PRE5901 instructions for details.7. Check the trigger is not active, if 216-253VAC is supplied to the TRIG terminal the thermostat will stay in boost mode until the voltage is disconnected.

Due to our policy of continuous improvement, we reserve the right to change specifications without notice. All information was correct at time of when this product file was produced - April 2020



Touch PIR auto-on 3 stage infra-red settable intelligent PIR thermostat with 7 day auto-on feature.

Cleverly simple control of energy.

TROUBLESHOOTING

FAULT	CHECK
The LED's are flashing and the buttons do not work	This is normal after first power up. The thermostat stays dormant for 1 minute while the PIR stabilises. Once this time has elapsed the unit will function as normal.
The load switches off after 2 minutes	The thermostat has a 2 minute test cycle/pre-warm, when the unit is boosted from setback or frost, or triggered via the PIR the thermostat will heat regardless of temperature for 2 minutes. Once this time run has elapsed the thermostat will resume temperature sensing. If the load is switching off after this time the temperature set-point is below that of the room temperature meaning there is no need for the load to be on.
The thermostat is always in boost mode	<ol style="list-style-type: none">1. Presence has been detected and boost mode activated. Once the room is vacated and the time run has completed the thermostat will return to setback mode.2. A mains voltage is present at the trigger (TRIG) terminal holding the unit in boost mode.3. Foreign substance jamming the up button.4. Auto-on is active. Programmed auto-on timings can be read using the PRE5901 handset. See PRE5901 instructions for details.
The thermostat does not enter boost mode when I enter the room	<ol style="list-style-type: none">1. The thermostat is in absence detection not presence detection. The thermostat will only boost when you enter the room if the detection mode is set to presence mode. For clarification of the PIR operating parameters see page 12.2. Your presence is out of range of the PIR. The maximum PIR detection range is 5 meters. See Page 5 for details3. The thermostat has been sited in an obstructed area.4. The PIR has been covered.5. The unit is not powered.



Cleverly simple
control of energy.

Touch PIR auto-on 3 stage infra-red settable intelligent PIR thermostat with 7 day auto-on feature.

PROGRAMMING CHARACTERISTICS

The time and temperature profiles of the unit are factory set to a default setting, however further adjustments can be made on site via the PRE5901 programming handset (Please note the PRE5900 and PRE5903 are not compatible with the ecostat2 range). Once the unit has been wired and fitted as instructed in this manual, power up the unit. The unit will be dormant for 1 minute after initial power up to allow the PIR sensor to stabilise.

LED INDICATORS

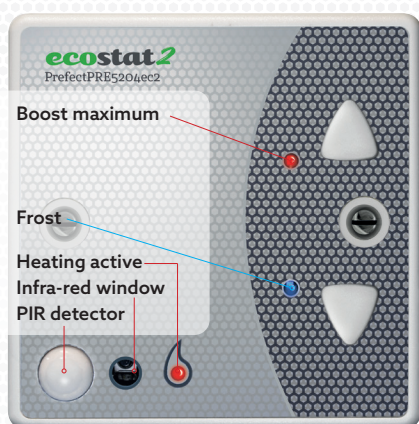

FROST - This mode is used for long periods of absence. A temperature of 5°C is recommended to protect the fabric of the building. Frost is activated once the setback time has elapsed. Frost mode can also be selected by pressing the down button until only the blue LED is lit.

USER ADJUSTMENT - The occupant can only select boost or frost mode.

PIR DETECTION MODES - In presence mode the thermostat will automatically boost when presence is detected. The thermostat will stay in boost mode until there is no longer presence detected and a settable run time has elapsed (boost mins). If after the time run elapses and presence is once again detected the thermostat will re-enter boost mode.

In absence mode the thermostat will not trigger when presence is detected. An up button press, time event or a trigger voltage is required to trigger the thermostat into boost mode. The thermostat will stay in boost mode until presence is no longer detected and the settable timer (PIR Time-out) run has elapsed, at which point the thermostat will enter setback

mode. To re-enter boost mode an up button press, time event or trigger voltage must be applied if none of these are applied during the setback time the unit will enter frost mode.

TEST MODE/PRE-HEAT -

When the thermostat is boosted by either presence detection, time event, mains trigger or an up button press the thermostat will enter boost mode. For the first 2 minutes of the boost cycle temperature sensing is omitted and the thermostat will heat regardless of temperature. After the 2 minutes has elapsed temperature sensing is re-enabled and the thermostat will continue the boost cycle. This cycle can take place only once during a boost cycle and once every hour unless the boost cycle is of more than an hour in which case the cycle can only take place once.

PROGRAMMING STATES

• **BOOST** - This mode is typically a relatively short run time, 45 to 120 minutes is recommended, with a comfortable room temperature used when the room is occupied of 20-23°C. The boost mode is activated either by the PIR sensing presence, the up button being pressed or the thermostat receiving a boost trigger voltage from an external source or an auto-on time event.

SETBACK - This mode typically uses a medium length run time, 12 to 48hrs is recommended. A temperature of 20-30% less than the boost temperature is recommended, this setting is used for short periods of absence. Setback mode is enabled when the boost run time has elapsed.

Due to our policy of continuous improvement, we reserve the right to change specifications without notice. All information was correct at time of when this product file was produced - April 2020

Touch PIR auto-on 3 stage infra-red settable intelligent PIR thermostat with 7 day auto-on feature.



Cleverly simple
control of energy.

PROGRAM CHARACTERISTICS

• PRESENCE MODE

When presence is detected the thermostat automatically enters boost mode. The thermostat can be manually returned to frost mode if required. After the boost time run has elapsed the unit will enter setback mode. If presence is once again detected or if the thermostat receives a trigger voltage or a time event occurs the unit will re-enter boost mode. If no presence or trigger voltage is present the thermostat will continue in setback mode until the settable run time has elapsed. Once the setback run time has elapsed the thermostat will enter frost mode. The thermostat will remain in frost mode indefinitely until the unit is triggered into boost by either presence or a mains voltage is present at the trigger terminal.

Whenever presence is detected the boost run time is reset to 0, meaning; if presence is detected boost mode will start and the timer will begin from 0, if the occupant leaves the room and returns and presence is detected again, the boost time will be reset to 0 and begin timing again. The thermostat will stay in boost mode as long as presence is detected. Presence mode is the best option for occupant comfort. **Absence mode is a more energy efficient mode.**

• ABSENCE MODE

In Absence mode (ABS) the thermostat will remain dormant until the up button is pressed or a 230VAC trigger voltage is applied to the trigger terminal or an auto-on time vent is triggered, the thermostat will enter boost mode. If the room is continuously occupied the thermostat will remain in boost mode until presence is no longer detected and the time run has elapsed. Once the boost time has elapsed the thermostat will enter setback mode. If the thermostat is in boost mode and the room is left unoccupied the thermostat will start the PIR time-out. PIR time-out is the length of time the thermostat will stay in boost mode once the room is unoccupied. For example if the PIR time out is set to 10 minutes, the thermostat will stay in boost mode while the room is occupied, once the room is unoccupied the PIR time out will begin the time run, if no presence is detected during the time out 10 minutes the unit will enter setback mode, if at any time during the 10 minutes someone enters the room, the PIR time out will be reset to zero, meaning the unit will stay in boost mode. If the room is occupied for 1 hour, the boost cycle will be active for the selected 30 minutes in this example then enter setback mode. Boost Time is how long the thermostat will stay in boost mode if the room is occupied. PIR time-out is how long the thermostat stays in boost mode when the room is vacated. If you wish to have the boost cycle complete regardless of absence, set the PIR time-out to the same value as the boost time. **Absence mode is the best option for energy saving.**



Cleverly simple
control of energy.

Instructions - page 15 of 24

Touch PIR auto-on 3 stage infra-red settable intelligent PIR thermostat with 7 day auto-on feature.

• 230VAC REMOTE TRIGGER

The thermostat can be remotely triggered into boost mode by applying a mains voltage to the trigger terminal (TRIG) on the thermostat. When the mains voltage is applied for less than 30 seconds the thermostat will enter boost mode, the thermostat will complete the boost run time. When the voltage is applied for more than 30 seconds the thermostat will stay in boost mode until the trigger voltage is disconnected. Once the trigger has been disconnected the thermostat will immediately enter setback mode and resume the normal program cycle. When the trigger voltage is active the PIR is omitted. The end user can cancel the boost trigger if desired. The 2 minute preheat/test cycle does apply to the live trigger.

• TIME EVENT AUTO-ON 7 DAY PROGRAMMING

Auto-on will trigger the thermostat into boost mode at 1 or 2 points during each day 7 days a week. The auto-on feature is programmed using the PRE5901 handset. Please note that a battery must be purchased and fitted into the thermostat (see page 23). Once the battery has been installed the real time clock must then be set. Clock setup is programmed via the PRE5901 handset (see PRE5901 instructions). Once programmed the thermostat will boost automatically at the set time and run the boost time. The thermostat's PIR is omitted during the auto-on cycle, meaning that the thermostat will heat whether presence is detected or not. Once the thermostat auto-on has triggered the thermostat will run the boost time. The 2 minute pre heat/test cycle applies to the auto-on cycle, the 2 minutes is inclusive of the boost time. When a time event is active the end

user can cancel boost mode by selecting frost mode. If a time event is required for more than the boost time, you can combine two time events to make 1 extended time event. For example if your boost time is 60 minutes and you desire the heating to be active from 09:00 until 10:30 you can set the first time event for 09:00 then set the second time event at 09:30 this will achieve a 90 minute run time. NOTE: the auto-on time events do not occur when the thermostat is in frost mode.

• OPTISTART

The thermostat has an optimum start feature. The optimum start feature ensures the room is at the required temperature at the set time event. The thermostat will learn how long it takes to raise the temperature of the room it is controlling. Using this information the thermostat will calculate how long before the time event the thermostat must start heating to achieve the boost temperature at the time event. This ensures the room is at the required temperature at the required time without having to set the time event early to ensure the room is to temperature, which may waste energy.

Touch PIR auto-on 3 stage infra-red settable intelligent PIR thermostat with 7 day auto-on feature.

Cleverly simple control of energy.

PROGRAM GRAPHS

The graphs below indicate the thermostats 3 mode temperature set points: boost, setback and frost modes. The graphs also show how the thermostat is triggered by the 4 boost triggers, these being a button press, mains trigger, auto-on time event and presence detection.

The graphs time is not to scale.

STANDARD PRESENCE ACTIVATED

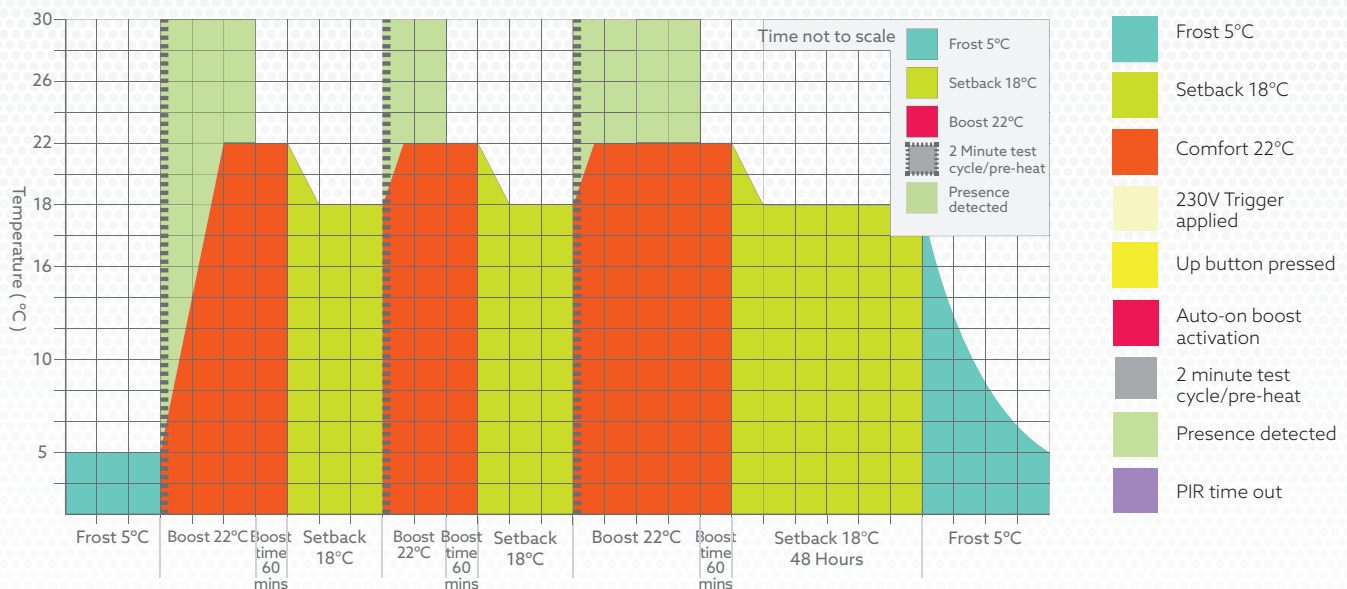

This graph shows how the thermostat reacts to presence, for this example the thermostat is set to the following settings:

- Frost 5°C
- Setback 18°C for 48 hours
- Boost 22°C for 60 minutes
- Detection mode - Presence
- Auto-on - disabled

When the thermostat detects presence the thermostat enters boost mode indicated in orange, the thermostat will heat, raising the temperature from 5°C to 22°C. The thermostat will stay at boost level while presence is detected. Once presence is no longer detected the thermostat will start the boost run time in this case 60 minutes. Once the 60 minute run time has

elapsed the thermostat turns down to setback mode, indicated in green, and the temperature drops to 18°C. The thermostat is now holding 18°C, the thermostat is now running the 48 hour setback time. During the setback time presence is detected again, the thermostat enters boost mode again, running the first 2 minute test/preheat with temperature sensing omitted. Once presence is no longer detected the thermostat runs the boost time of 60 minutes, then once again enters setback mode. Once again presence is detected and the thermostat enters boost mode, then when presence is no longer detected the 60 minute boost time is run. Once complete the thermostat re-enters setback mode and maintains 18°C. In the following 48 hours no presence is detected, once 48 hours has elapsed the thermostat enters frost mode indicated in blue.

Due to our policy of continuous improvement, we reserve the right to change specifications without notice. All information was correct at time of when this product file was produced - April 2020

Touch PIR auto-on 3 stage infra-red settable intelligent PIR thermostat with 7 day auto-on feature.

Cleverly simple control of energy.

PROGRAM GRAPHS

STANDARD ABSENCE ACTIVATED

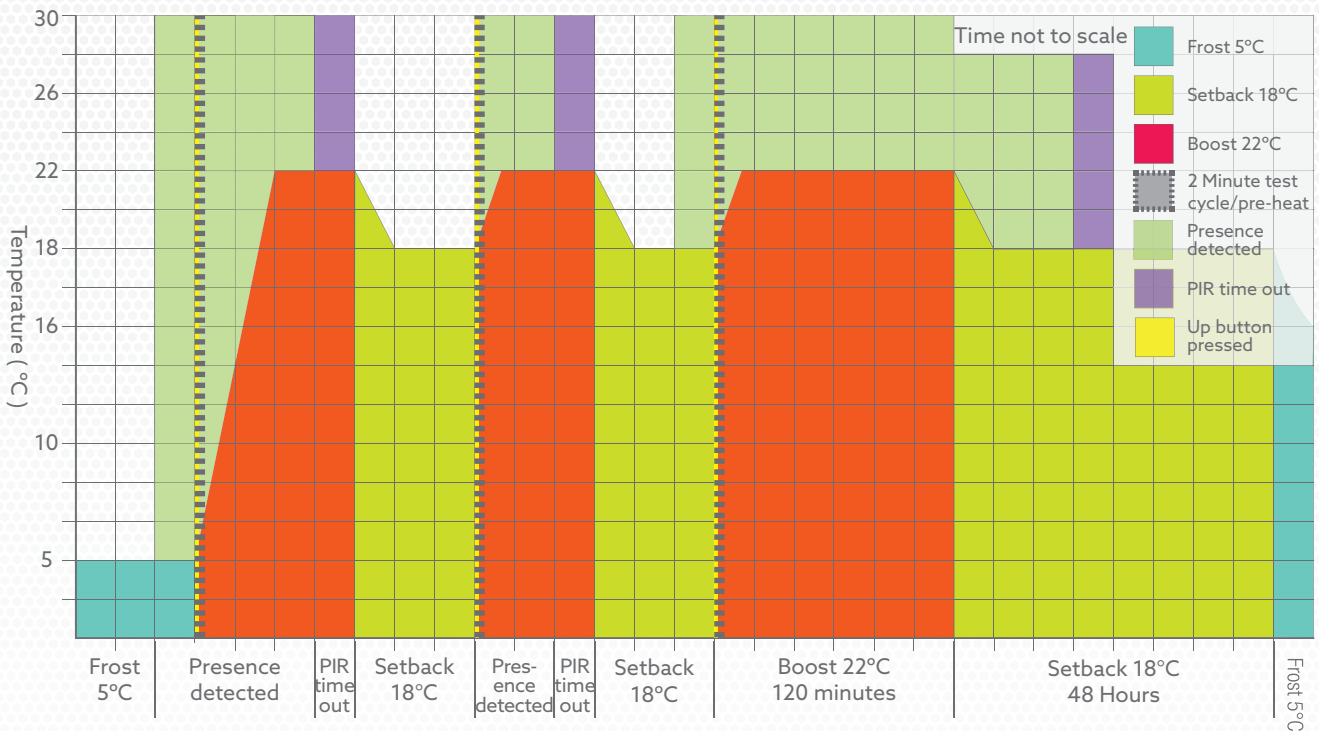

This graph shows how the thermostat reacts to absence, for this example the thermostat is set to the following settings:

- Frost 5°C
- Setback 18°C for 48 hours
- Boost 22°C for 120 minutes
- Detection mode - Absence
- PIR time out - 20 minutes

The thermostat starts in frost mode, when presence is detected the thermostat takes no action, when set to presence mode the thermostat would enter boost mode. The up button is then pressed boosting the thermostat to the maximum level of 22°C. Then presence is no longer detected, the thermostat will start the PIR time out. PIR time out is the settable length of time the thermostat will stay in boost mode

before returning to setback when presence is no longer detected, when set to presence mode the thermostat will run the boost time. The PIR time out completes and the thermostat turns down to setback mode at 18°C, the setback time starts running. Before the setback time has completed the up button is pressed, again boosting the thermostat to maximum, when presence is no longer detected the thermostat runs the PIR time out. Once completed the thermostat again enters setback mode. Presence is detected, the thermostat takes no action. The up button is pressed again. This time presence is detected for more than the boost run time. The thermostat will only run the boost time completing the 120 minute run time then returning to setback mode. When set to presence mode the thermostat will stay in boost mode as long presence is detected.

Due to our policy of continuous improvement, we reserve the right to change specifications without notice. All information was correct at time of when this product file was produced - April 2020



Touch PIR auto-on 3 stage infra-red settable intelligent PIR thermostat with 7 day auto-on feature.

Cleverly simple
control of energy.

SPECIAL FUNCTIONS

• VALVE SERVICE CYCLE

The valve service cycle is a feature that allows you to operate a heating control valve periodically to maintain movement and prevent a valve from seizing. The valve service cycle can be set from 1 to 30 days. The thermostat will operate the valve for 5 minutes closing and opening the valve, this will occur once in the set time period. The valve service cycle default is set to 0, when set to 0 the valve service cycle is deactivated, to enable the feature use the PRE5901 Handset and navigate to Heating>Select Product>PRE5000ec2>Device Config>Valve Service Cycle (days) change the value from 0 to a required time in days.

• LED FALLBACK

The LED indicators on the thermostat will illuminate to maximum brightness when the thermostat is boosted by a button press, mains trigger, time event or presence detection. The LEDs will dim after the state change, the duration the LEDs stay at maximum brightness before dimming and how far the LEDs dim is settable using the PRE5901 handset. Using the PRE5901 handset navigate to Heating>Select Product>PRE5000ec2>LEDs Fallback. Brightness is the percentage of power the LEDs will dim to, a lower percentage meaning a dim LED and vice versa. This value is settable to 10, 20, 30, 40 or 50% brightness 50% being the brightest. Time (secs) is the duration of time the LEDs will stay at maximum brightness after a state change, this is settable between 1 and 120 seconds.

• WINDOW OPEN DETECTION

The window open detection detects an unusual drop in temperature and limits the output to the heater/radiator/boiler. This feature monitors temperature over a set period of time, if in this time the room temperature drops below a set level the thermostat will enter window open detection mode. While in this mode the thermostat limits output to the heater/radiator, this is a settable value of time called duty cycle. The thermostat does not limit power to the heater/radiator/boiler it simply reduces the amount of time the load is on. There are 3 settings for this feature, Time (mins), Temp (C) and Duty Cycle (mins). The time setting is the length at which the thermostat looks for a temperature drop. The temp setting is how many degrees the room temperature must drop in the selected time frame to activate window open detection mode. Duty cycle is how long the heater/Radiator/boiler can be active for when the window open detection mode is active. When the duty cycle is set to 5 minutes the heater/radiator/boiler will be on for 5 minutes and off for 5 minutes. Window open detection mode only functions during the boost cycle, it is not active in setback or frost mode. When window open detection mode is active the top and bottom scale LEDs will flash alternately. To exit window open detection mode press the up button once. Once the up button is pressed the mode is deactivated and the thermostat will continue to monitor temperature. If the temperature increases the boost cycle will continue if the temperature does not increase window open will be reactivated. If the temperature drops below the detection point within the time frame again the window open detection will be reactivated.

Touch PIR auto-on 3 stage infra-red settable intelligent PIR thermostat with 7 day auto-on feature.

Cleverly simple control of energy.

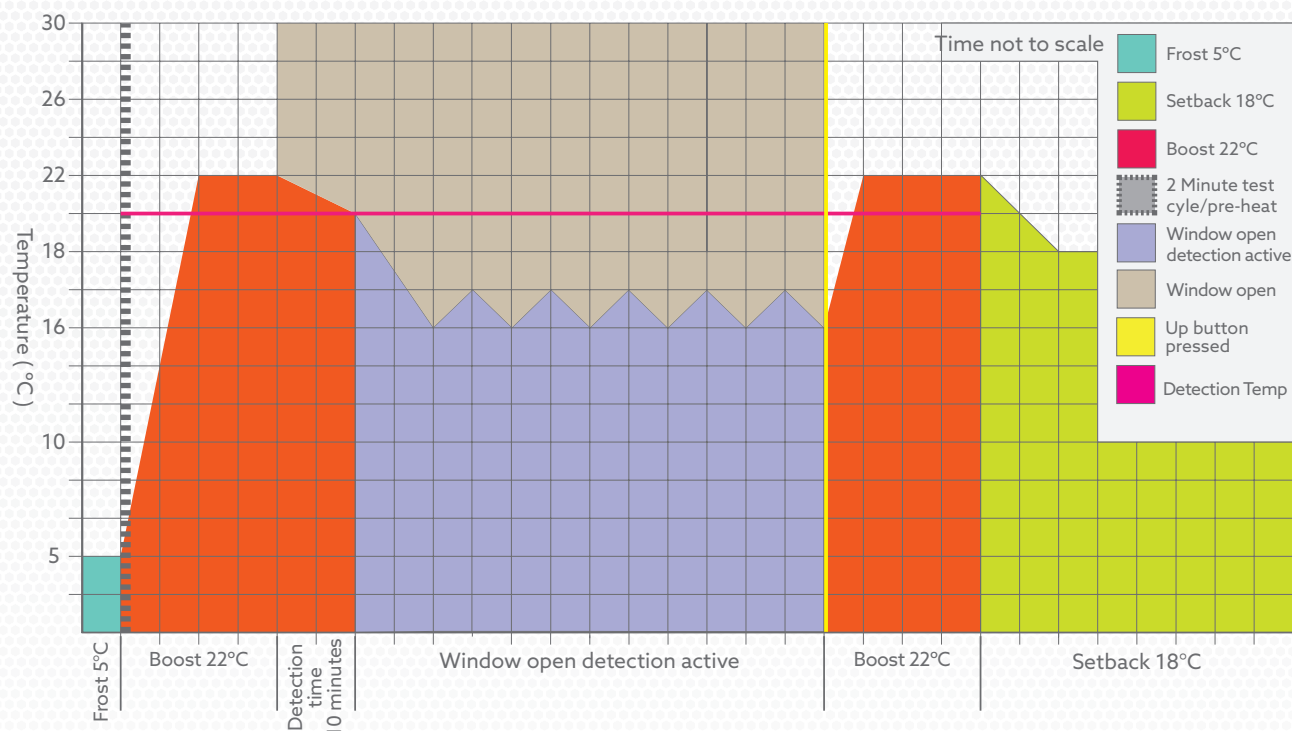

In the example above the thermostat is set to the following settings:

- Boost 22°C
- Setback 18°C
- Window open detection time 10 minutes
- Window open detection temp 2°C
- Window open detection duty cycle 5 minutes

The thermostat is boosted to 22°C, during the boost cycle the window is opened (indicated in brown). during a 10 minute period the temperature drops by 2°C. This activates the window open detection mode, the thermostat limits output to 5 minutes off 5 minutes

on. When the window is closed and the up button is pressed (indicated by the yellow line), the window open detection mode is deactivated and the temperature is restored to 22°C for the remainder of the boost cycle. Normal program operation resumes. If the up button is pressed and the temperature continues to drop, window open detection mode will be reactivated.

Settings can be found on the handset here:

Heating>Select Product>PRE5000ec2>Window Open Detect.

This feature is enabled by default, this feature can be disabled in the aforementioned menu.

Touch PIR auto-on 3 stage infra-red settable intelligent PIR thermostat with 7 day auto-on feature.

Cleverly simple
control of energy.

PROGRAMMING:

All thermostat parameters are set via the PRE5901 programming handset. Please note that the other Prefect IR handsets are not compatible with the ecostat2 series. For instructions on how to program the ecostat2 range and other Prefect infra-red products please see the PRE5901 instructions, available upon request or visit: www.prefectcontrols.com look under the products tab for Handsets and select PRE5901.

SENDING OR READING SETTINGS AND COMMANDS:

To install settings into a product the settings must be "sent".

Settings can also be "read" from the product.

The settings are sent and read via an infra-red (IR) transmitter and receiver in the top of the handset.

The settings are received by a infra-red (IR) receiver on the product.

The infra-red is direct line of sight, meaning there must be a clear path between the handset and the product to be set.

The product to be set must be powered, the product can be set at anytime regardless of its current process. Installation of the settings is immediate.

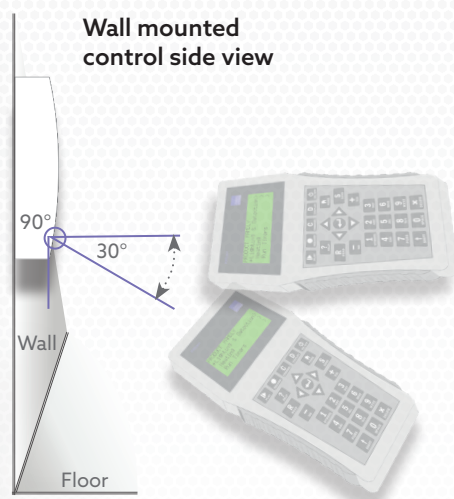

Point the top of handset at the IR window of the control (see page 13).

As above hold the handset between 90 and 30 degrees from the wall.

Hold the handset between 30cm to 3m from the control.

The handset only needs to be pointed at the thermostat while the settings are being sent or read.

The handset needs to be kept pointing towards the thermostat until the read or send function is complete.

Short pressing the send or read key will read the current selected parameter. For example if the boost time is

highlighted and the read button is pressed, only the boost time is read.

Long (press & hold) pressing either the send or read key, will send or read all parameters in one operation.

Keep the send or read key pressed until the handset sounds a bleep to confirm all parameters have either been read or sent.

The handset must be kept pointing towards the control during this operation until the beep is heard.

The thermostat will blink it's LEDs to confirm infra-red contact. If the LED does not light the infra-red signal is not being received, adjust the angle and or the distance of the handset until the control receives the commands.



Cleverly simple
control of energy.

Touch PIR auto-on 3 stage infra-red settable intelligent PIR thermostat with 7 day auto-on feature.

PROGRAMMING PARAMETERS

PARAMETER	VALUE	FACTORY SETTING	DESCRIPTION
TEMPERATURE			
Frost (°C)	0-40°C	5°C	Frost temperature.
Setback (°C)	0-40°C	18°C	Setback temperature.
Boost (°C)	0-40°C	23°C	Boost Temperature.
Setback (hrs)	1-336 Hrs	6 Hrs	Timer run between boost mode ending and frost mode starting.
Boost (mins)	1-999 Mins	45 Mins	Boost run time. Does not apply when boosted by trigger for more than 30 secs.
Setback (mins)	1-59 Mins	0 Mins	For use when a setback time of less than 1 hour is required. Can also be used with setback hours for a higher time resolution, for instance 2 hours 45 minutes.
Current T (°C)	°C		Current room temperature as read by the thermostat.
PIR			
Detection Mode	Presence (Pres) or absence (Abs)	Abs	Detection mode for the PIR.
Time-out	0-999 Mins	5 Mins	Time-out only applies to Absence mode. Time-out is the length of time the thermostat will maintain boost level after an occupant has left the room. For example if the room is occupied and in boost mode, when the occupant leaves the room the PIR time out begins, when the PIR time out time elapses the thermostat will enter setback mode. If at any point during the PIR time out the occupant returns the PIR time out will be reset to zero and the boost mode will be maintained.
CLOCK			
Day	Mon, Tue, Wed, Thu, Fri, Sat, Sun	-	Current day.
Time	00:00	0	Current time, in a 24 hour format.
Summer (+1 hr)		0	Advances the real time clock by 1 hour.
Winter (-1 hr)		0	Retards the real time clock by 1 hour.
Opti-Start enabled	Yes, No	No	Enables on or off for Opti-Start.
Max start Re-learn	1-60 Mins	60 Mins	Maximum start time for heating before scheduled timed event. Enables re-set so unit re-learns the thermal dynamics of the room to assess warm up time required.
EVENTS			
Day	Mon, Tue, Wed, Thu, Fri, Sat, Sun	-	Day in which the time event is to take place.
Event 1	Enabled, Disabled 00:00	0	Event 1 time and whether or not the time event is enabled.
Event 2	Enabled, Disabled 00:00	0	Event 2 time and whether or not the time event is enabled.

Due to our policy of continuous improvement, we reserve the right to change specifications without notice. All information was correct at time of when this product file was produced - April 2020



Cleverly simple
control of energy.

Touch PIR auto-on 3 stage infra-red settable intelligent PIR thermostat with 7 day auto-on feature.

PROGRAMMING PARAMETERS

PARAMETER	VALUE	FACTORY SETTING	DESCRIPTION
ADVANCED FEATURES			
WINDOW OPEN DETECTION			
Enabled	Yes, No	Yes	Select if the window open detection is enabled.
Time (mins)	1-60 Minutes	20 Mins	The time duration of how long the detection period is.
Temp (C)	1-10°C	2°C	The required temperature drop within the detection time.
Duty Cycle (mins)	5-60 minutes	10 Mins	The duty cycle when the window open mode is active.
BOOST TRIGGER			
Time Event	Min, Med, Max	Max	Level of boost selected when a time event occurs.
Mains Trigger	Min, Med, Max	Max	Level of boost selected when a mains trigger is applied.
PIR Presence	Min, Med, Max	Max	Level of boost selected when presence detected.
LEDs FALLBACK			
Brightness %	10, 20, 30, 40, 50	20%	Brightness of LEDs once they have dimmed.
Time (secs)	1-120 seconds	5 Secs	How long the LEDs will remain at full brightness before dimming.
DEVICE CONFIGURATION			
Deep Sleep	Yes, No	?	Disables time keeping for periods with no mains power for battery conservation
Valve Service Cycle (days)	0-30 Days	-	Amount of days between a valve service cycle.
IR enabled	Yes or No	YES	Disables the infra-red setup from further adjustment without first re-enabling the infra-red. For instance when the infra-red is disabled the thermostat will not accept any settings until infra red is re-enabled. This can also be used for when 2 thermostats are in close proximity and require different settings.
Enable Mains Trigger	On, Off	On	Restarts the thermostat without altering any stored settings.
Soft Reset			Restarts the thermostat without altering any stored settings.
Factory Reset	AR-PRE5000		Returns all parameters of the thermostat to default settings, the handset settings are not changed.
TEMPERATURE			
Offset(C)	-1.5 to 1.5	0.0	Temperature calibration offset. Use this feature to offset the temperature calibration. For example if the thermostat is mounted on a cold wall and is measuring a degree less than the centre of the room, set the offset to -1°C.

Due to our policy of continuous improvement, we reserve the right to change specifications without notice. All information was correct at time of when this product file was produced - April 2020

Touch PIR auto-on 3 stage infra-red settable intelligent PIR thermostat with 7 day auto-on feature.

Cleverly simple control of energy.

BATTERY CELL FITMENT & REPLACEMENT

The thermostats battery cell is required for operation of the auto-on feature. Once the battery cell has been depleted the auto-on feature will cease to function. However the thermostats other functions will not be affected and will continue to operate as normal. Please note that when the battery cell has been depleted only the current time is lost, all other settings are saved in the thermostats non-volatile memory.

Before undertaking any servicing work on the thermostat it is imperative that the mains supply to the thermostat and any trigger voltages have been safely isolated and locked off.

1. Perform safe isolation procedure.
2. Remove the thermostat from the fixing box.
3. Ensure there are no voltages present at any of the terminals.
4. Using a pair of electrical cutters, clip the 4 tabs on the top right battery cover and remove the cover(see fig 1).
5. Remove the battery retaining clip by removing the small machine screw, be sure to keep the screw in a safe place.
6. Remove the battery cell and dispose in an appropriate manner.
7. Insert the new battery cell, ensure the battery cell is inserted with the negative pole facing the negative pad on the PCB and the positive pole facing outwards.
8. Insert the retaining clip and replace the machine screw. Do not over tighten the fixing screw.
9. Ensure no conductors have been displaced during works.
10. Fit the thermostat back into it's fixing box.
11. Re-energise the supply circuit and any trigger circuits.
12. Check the thermostat is functioning correctly.
13. Using the PRE5901 programming handset, input the current time.

Fig 1

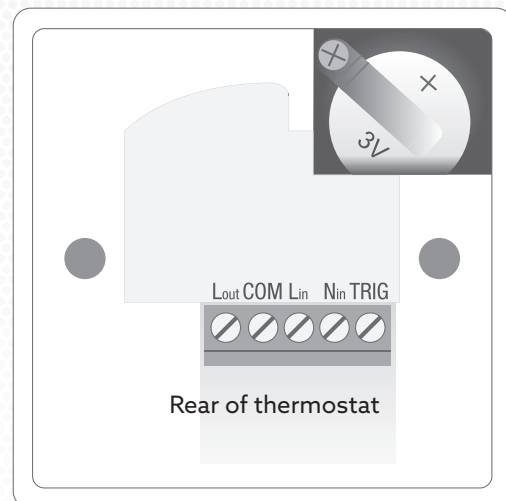
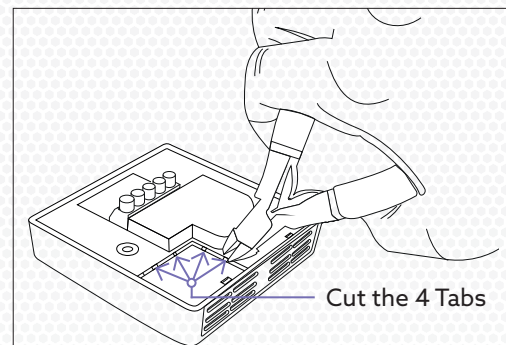

Battery cell fitted

- Battery cell
- Retaining Clip
- Self-tapping screw

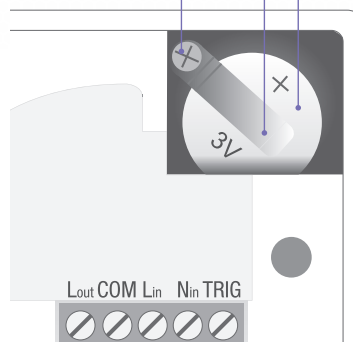

Battery cell removed

- Battery cell negative (-) pad
- Fixing screw mounting hole

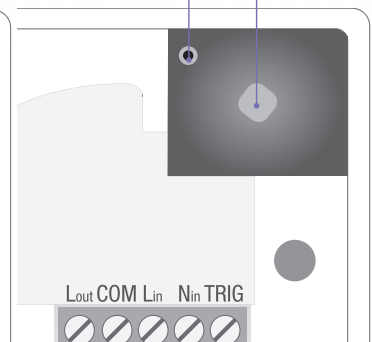

Due to our policy of continuous improvement, we reserve the right to change specifications without notice. All information was correct at time of when this product file was produced - April 2020



Cleverly simple
control of energy.

Touch PIR auto-on 3 stage infra-red settable intelligent PIR thermostat with 7 day auto-on feature.

FREQUENTLY ASKED QUESTIONS

Can I mount the thermostat in a bathroom?

The thermostat is IP3X rated, therefore the thermostat can be mounted in zone 3.

Where do I mount the thermostat in a disabled room?

Mount the thermostat as close as possible to the central point of the room allowing for wheel chair access. Mount 1200mm from finished floor level.

Can I use two thermostats in the same room?

This is not recommended as the thermostats will contradict each other. The recommended solution is to control multiple heaters with a single thermostat. The thermostat can switch a combined heating load of up to 3.4kW. For a wiring diagram please visit prefectcontrols.com or contact a member of our staff. For loads above 3.4kW a contactor must be used.

Where do I mount the thermostat if it is controlling a boiler or heaters in multiple rooms?

When controlling multiple rooms mount the thermostat at the most central point between the rooms. Can I mount the thermostat next to the heater/radiator. The thermostat can be mounted next to the heater/radiator but must not be mounted within 300mm of the nearest edge of the heater and must not be mounted above the heater.

Can I mount the thermostat next to the heater/radiator?

The thermostat can be mounted next to the heater/radiator but must not be mounted within 300mm of the nearest edge of the heater and must not be mounted above the heater/radiator.

Can I use the thermostat to control a LV or 0V circuit?

Yes, the thermostat has a volt free contact, simply remove the supplied mains link that is fitted between the Lin and COM terminals. Terminate your LV or 0V supply to the COM terminal. Terminate the return to the Lout terminal.

Do I need any extra wiring accessories?

Yes, the thermostat must have a local means of safe double pole isolation. A PRE6000 double pole key switch is recommended. The thermostat must be mounted in a suitable 30mm or greater surface or sunken single gang box.

What is the live trigger for and do I have to use it?

When a mains voltage is applied to the trigger terminal the thermostat will enter boost mode. This allows the

thermostat to be boosted by an external device such as a door switch, card reader or timer. This function is optional and does not need to be connected.

Do I have to connect an earth to the unit?

The thermostat does not have an earth connection as the unit is double insulated. Current regulations state that there should be an earth present at the back box. If available terminate the earth to the terminal in the back box. If no such terminal is present safely terminate the earth into a terminal block or Wago and leave in the back box.

What cable should I use to connect the thermostat?

Cable type and size is dependant upon installation configuration, ensure the cabling has appropriate load carrying capacity and conforms with regulations in force at time of installation. We recommend using a 3 and earth cable.

How do I change the settings?

Settings are changed via the infra-red programming handset the PRE5901. See page 20.

How much control does the end user have?

The end user can only select temperature set points frost or boost.

Can the end user change the settings?

No the thermostat is tamper proof, the settings can only be changed by the handset.

Do I have to use the clock function?

No each time event can be activated or deactivated via the handset. See page 15.

Do I have to use Optistart?

No, the Optistart feature can be deactivated using the handset. See page 15.

Do I have to use the window open detection?

No, the window open detection can be deactivated using the handset. See page 18.

Do I have to use the PIR?

Yes, The PIR cannot be disabled. However to make the thermostat to operate by button press only set the thermostat to absence mode and the PIR time out to the same as the boost time.